

**Jules**

**Wabbes**



**Jules Wabbes**  
GENERALDECORATION

# **OUR PHILOSOPHY**

**Through our collaboration with the best craftsmen in Belgium and by servicing Trade Professionals, Architects and Interior Designers, we guarantee our most demanding clientele that our objects are real pieces of art, respectful of the original design by Jules Wabbes, and manufactured with the highest standards of quality.**

**All of our objects were designed by Jules Wabbes.  
Since 1969 GENERAL DECORATION has manufactured these objects  
by strictly following the original blueprints and drawings.  
GENERAL DECORATION works with the best craftsmen in Belgium  
and uses noble materials respectful of Jules Wabbes' choices.  
Each piece is numbered and certified.**



END GRAIN DINING TABLE





## TECHNICAL SPECS

NAME End Grain Dining Table  
 REF W2276  
 ORIGINAL DESIGN 1966

MATERIAL Raw Bronze, Wenge  
 DIMENSIONS Made-to-measure  
 Diameter: 1500 to 2200 [mm] /  
 59.06 to 86.61 [""]  
 Height: 730 mm / 28.75"

WEIGHT  
 Base: 100 kg / 220.46 lbs  
 Tabletop: 90 kg / 198.42 lbs

PRODUCTION / EDITION On Demand

The round table was one of Jules Wabbes' favourite creations. It was specifically designed for the house of a private client in Antwerp in 1966. The thick tabletop is made of rectangular blocks of wenge (*Millettia laurentii*) glued together to form an end grain board.

The palette of dark brown is wonderfully warm, sober, and subtle.

The End Grain Dining Table was inspired by a traditional technique of wood joint utilised notably for butcher blocks.

It requires tools and a great technique to make such a tabletop because it has nothing to do with marquetry. Rather, the pieces of wood are thick enough to form a free-standing shelf. The first essays on end grain wood were made by Wabbes in the early 1960s. This kind of joint is rarely utilized for large tabletops like this.

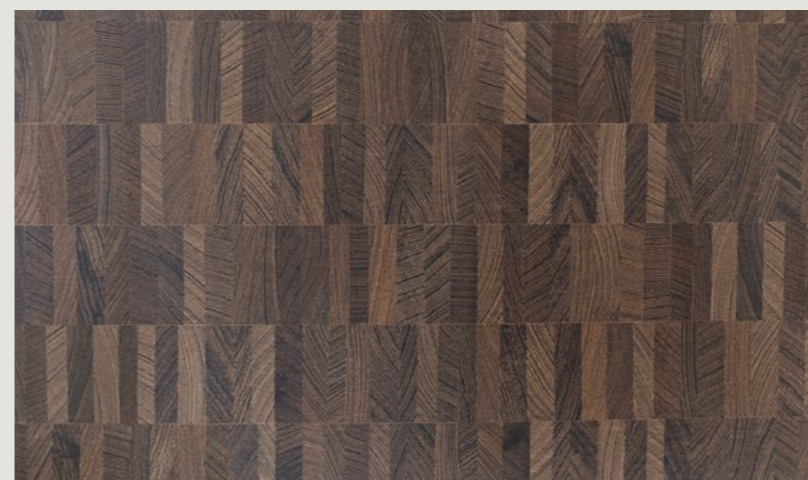
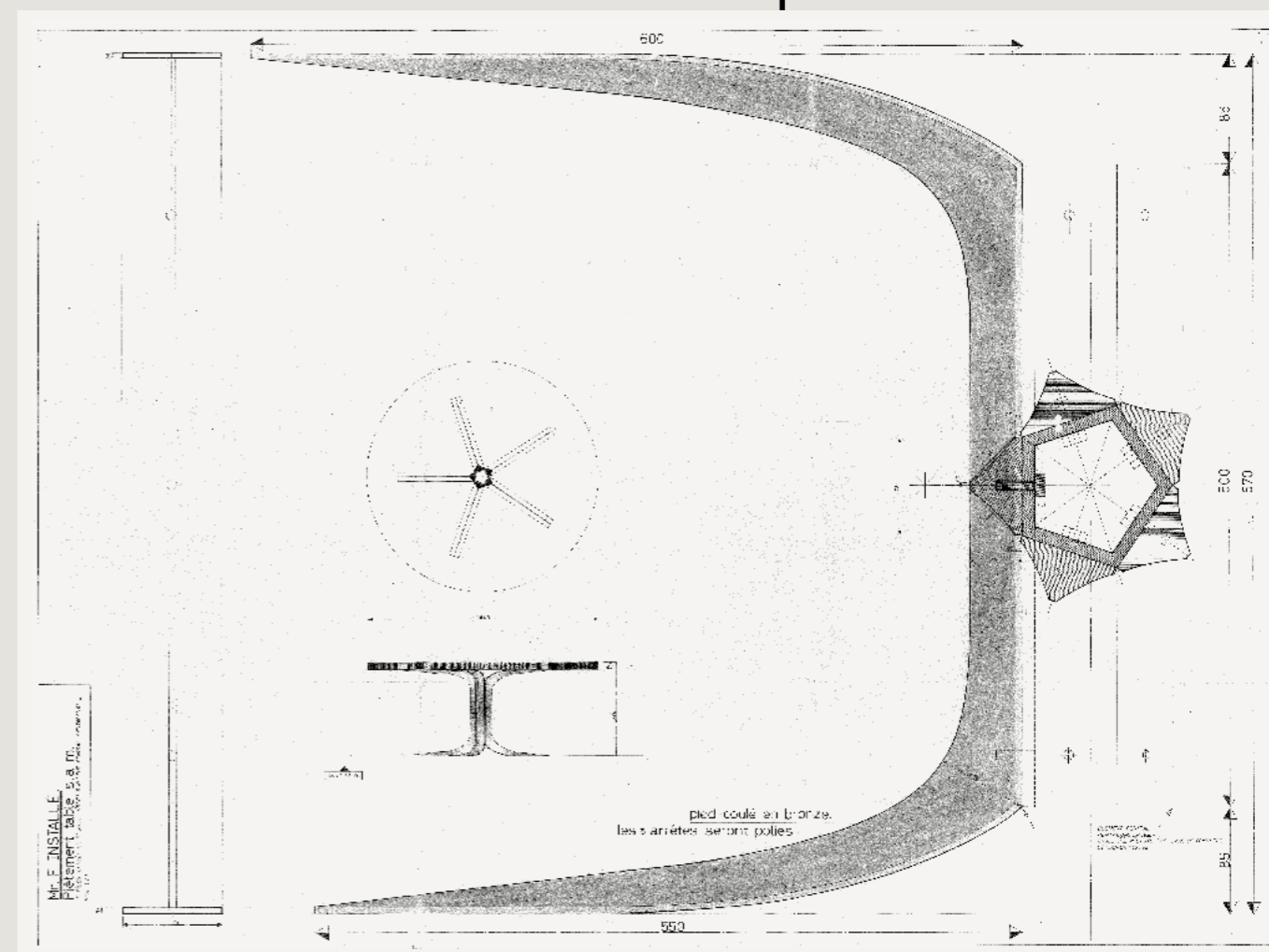

In addition, the use of wenge, an African wood that is extremely solid, dense, and dark, is one of his trademark creations.

The base is composed of five raw bronze cast elements screwed onto a central pentagonal shaft. Each element has a triangular, but curved, section whose three edges are polished. A subtle detail that lightens and emphasises the structure.

A central table pedestal is most convenient, as none of your guests will experience the discomfort of being squeezed by an outside or lateral table leg.

This table was conceived as a tribute to wood and metal. It will shine in your home and last forever.

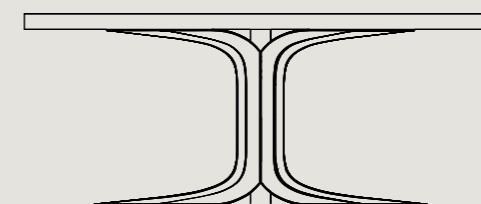

# LIFESTYLE

---

## LAMPS

Honeycomb Wall Lamp	P.16-19
Honeycomb Ceiling Lamp	P.20-23
Mini Wall Lamp	P.24-27
5-Band Wall Lamp	P.28-29
11-Band Wall Lamp	P.30-31
Osaka Ceiling Lamp	P.32-33
Round Brass Pendant	P.34-37
Hexagonal Table Lamp	P.38-51
Bronze Wall Lamp	P.52-71
Garden Lamp	P.72-73

---

## COAT PEGS & COAT RACKS

Coat Peg	P.74-77
Butterfly Coat Rack	P.78-79
Slatted Coat Rack	P.80-83

---

## TRESTLES

Trestles	P.84-89
----------	---------

---

## ACCESSORIES

Trinket Bowl	P.90-91
--------------	---------

---

## FIRE ACCESSORIES

Firedogs	P.92-93
Fire Belt	P.94-95
Fire Basket	P.96-98

---

**GENERAL DECORATION  
BY JULES WABBES**





HONEYCOMB WALL LAMP | HWL

LEFT: Nickel-plated Brass | HWL-NPB  
ABOVE: Polished Brass | HWL-PB

HONEYCOMB WALL LAMP [see P.144](#)

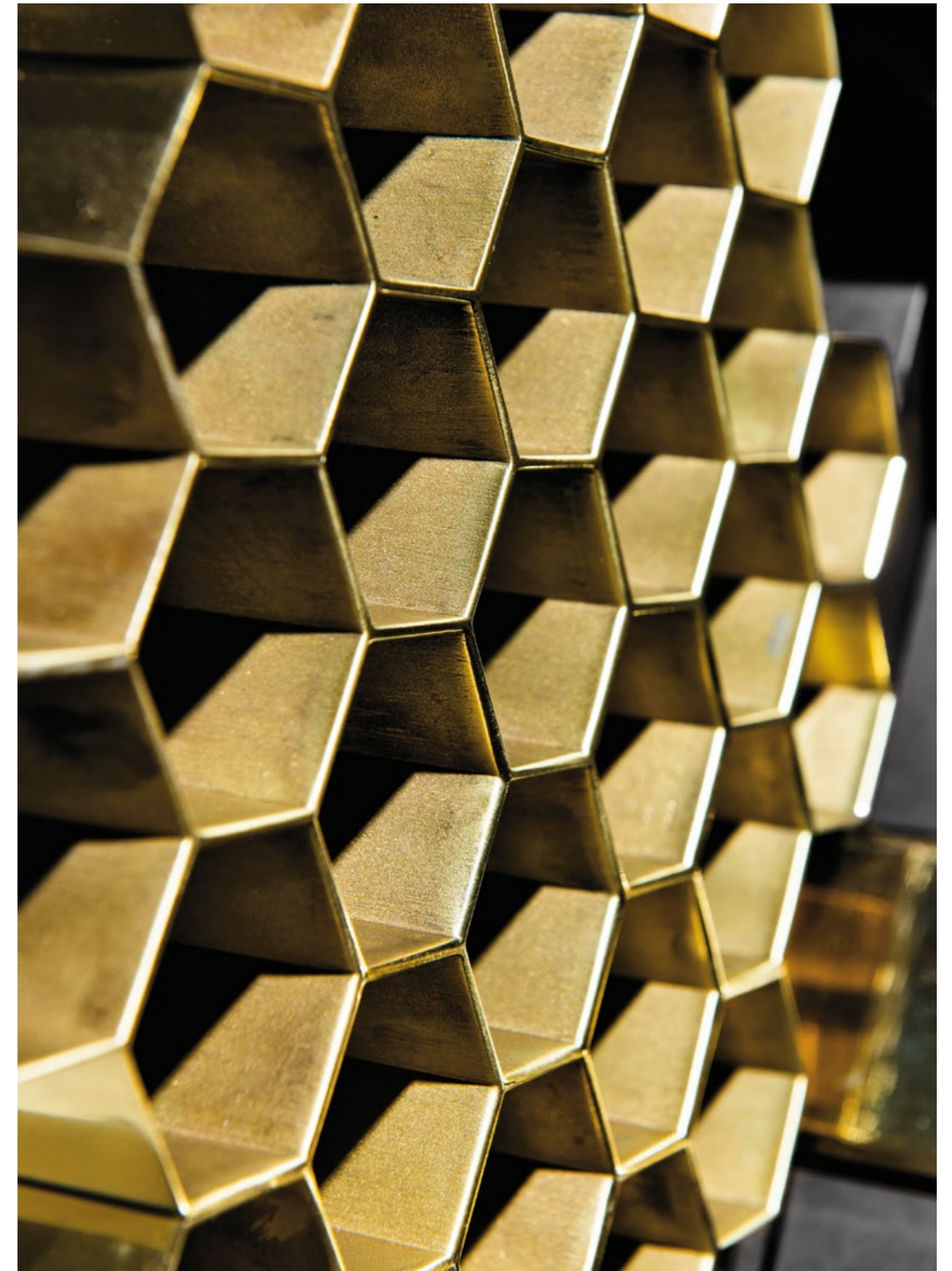

HONEYCOMB WALL LAMP | HWL

LEFT AND ABOVE: Polished Brass | HWL-PB

HONEYCOMB WALL LAMP

[see P.144](#)





HONEYCOMB CEILING LAMP | HCL

PREVIOUS PAGE: Polished Brass, front view  
LEFT & ABOVE: Polished Brass,  
bottom and front view | HCL-PB

HONEYCOMB CEILING LAMP

see [P.146](#)



MINI WALL LAMP | MWL

LEFT & ABOVE: Polished Brass | MWL-PB

MINI WALL LAMP

[see P.154](#)





MINI WALL LAMP | MWL

ABOVE & RIGHT: Nickel-plated Brass | MWL-NPB

MINI WALL LAMP

[see P.154](#)



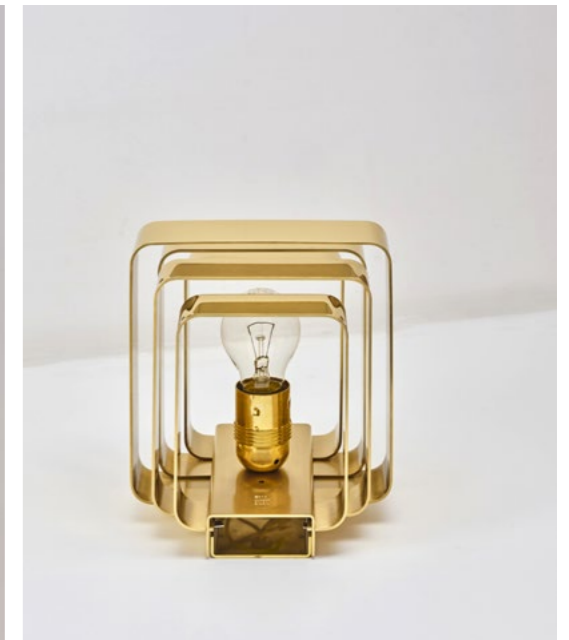

5-BAND WALL LAMP | 5BWL

LEFT: Nickel-plated Brass | 5BWL-NPB  
ABOVE: Polished Brass | 5BWL-PB

11-BAND WALL LAMP | 11BWL

NEXT PAGE: Nickel-plated Brass | 11BWL-NPB

5-BAND WALL LAMP  
11-BAND WALL LAMP

see P.156  
see P.158









OSAKA CEILING LAMP | OCL

PREVIOUS PAGES: Brushed Brass | OCL-BB

LARGE ROUND BRASS PENDANT | LRP

RIGHT: Brushed Brass | LRP-BB  
 ABOVE: Polished Brass | LRP-PB

OSAKA CEILING LAMP  
 ROUND BRASS PENDANT

[see P.150](#)  
[see P.152](#)





SMALL ROUND BRASS PENDANT | SRP

LEFT: Nickel-plated Brass | SRP-NPB  
 ABOVE: Polished Brass | SRP-PB  
 RIGHT: Nickel-plated Brass | SRP-NPB

ROUND BRASS PENDANT

[see P.152](#)





LARGE HEXAGONAL TABLE LAMP | W1005

PREVIOUS PAGE & LEFT: Raw Bronze | W1005-R  
RIGHT: Patinated Bronze | W1005-PT

HEXAGONAL TABLE LAMP

[see P.118](#)



LARGE HEXAGONAL TABLE LAMP | W1005  
 LEFT & RIGHT: Patinated Bronze | W1005-PT  
 HEXAGONAL TABLE LAMP [see P.118](#)





SMALL HEXAGONAL TABLE LAMP | W1025

LEFT: Raw Bronze | W1025-R  
RIGHT: Burgundy | W1025-B

HEXAGONAL TABLE LAMP [see P.118](#)



SMALL & LARGE HEXAGONAL TABLE LAMP | W1025 & W1005

LEFT: Polished Bronze | W1025-P

RIGHT: Raw Bronze & Patinated Bronze | W1025-R & W1005-PT

HEXAGONAL TABLE LAMP

[see P.118](#)







**IN 2019 GENERAL DECORATION,  
FOUNDED IN 1969 BY JULES WABBES,  
CELEBRATED ITS 50th ANNIVERSARY**

General Decoration, the company, producing the original design pieces of Jules Wabbes, celebrates its 50th anniversary in 2019. Still active today, GENERAL DECORATION enlarges its catalogue and develops new objects, lamps, decoration accessories and furniture each year, according to Wabbes' design.

General Decoration, "GEDE" for those who are familiar with it, has been directed since the death of its founder in 1974 by his wife Marie Wabbes, who always believed in his pieces, but never had either the time or the expertise to take care of it.

With the arrival of Vincent and Caroline as directors being in direct contact with the Wabbes family, the company got a new boost in 2014. It is now the reference for the production of metal pieces designed in the '50s and '60s.

Texts by  
Marie Ferran Wabbes

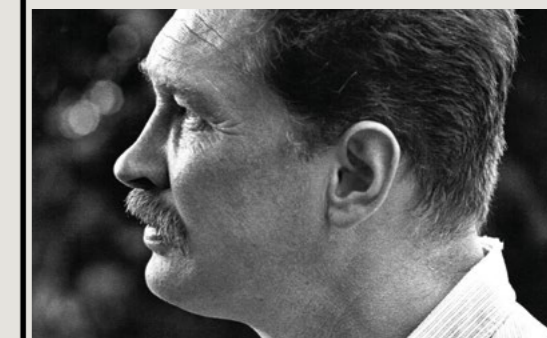

**IN 2019 ON MARCH 18th, JULES WABBES,  
THE BELGIAN DESIGNER, WOULD HAVE  
CELEBRATED HIS 100TH BIRTHDAY.**

He died at the age of 54 in 1974. Had he lived, he would have turned 100 in 2019 like the Bauhaus. Wabbes was not affiliated to any school, but the Bauhaus certainly had a major influence on every designer.

Wabbes was a free spirit who started his career as a photographer and antique dealer.

While restoring antique furniture, Wabbes was quite influenced by his close friendship with abstract painters (Georges Carrey, Serge Vandercam, Enrico Castellani to name a few) and William Menzel, a sculptor trained by Henry van de Velde, who all invited him to engage in designing modern furniture in the early '50s.

HEXAGONAL TABLE LAMP

LEFT & NEXT PAGES:  
*Gris des Ardennes* Belgian Marble  
W1005-EDL

SPECIAL EDITION

see P.120

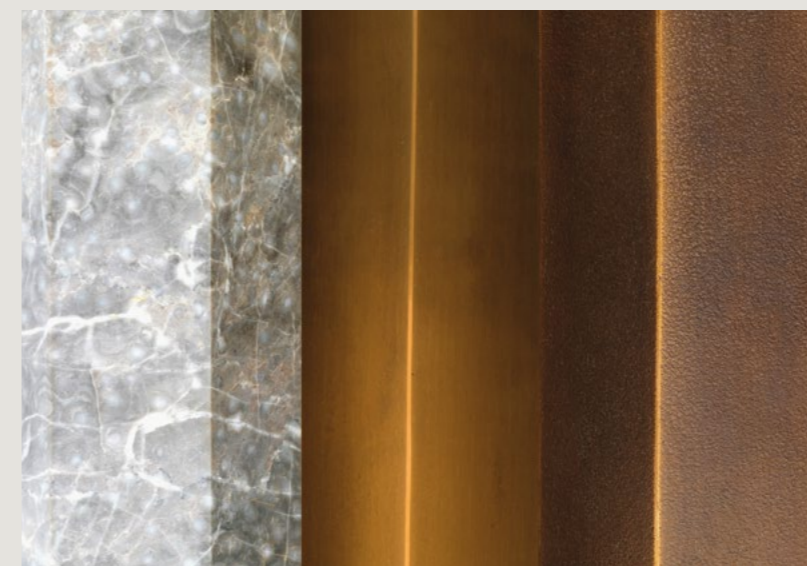



For Wabbes, above all, it is the material that counts. In the early '70s Wabbes already acquired the marble from De Merbes Sprimont. «This is the reason why we wanted to use stone again and most of all tell a Belgian story» say Vincent and Caroline. "When Isabelle Croonenberghs (Cromarbo) showed us the Belgian *Gris des Ardennes* marble we had our story!"  
Production is limited to 50 pieces.



At the time Jules Wabbes was an antique dealer, he transformed antique Chinese celadon vases into lamps. The early model of the Hexagonal Table Lamp was produced in ceramic, this is how he developed the fixation system of the lamp bulb and the shade. He asked his friend pottery artist Antoine de Vincke for a lamp stand in terra cotta.

Jules Wabbes also designed the same lamp in travertine stone, and finally in 1969, he developed the raw and polished bronze models.







SMALL BRONZE WALL LAMP | W1003

PREVIOUS PAGES: small exterior, Raw Bronze | W1003-R  
 ABOVE & RIGHT: small interior/exterior,  
 Raw Bronze | W1003-R & W1004-R

BRONZE WALL LAMP

[see P.108](#)





BRONZE WALL LAMP, TRESTLES, COAT PEG  
W1003, TR450, W1016

LEFT:

BRONZE WALL LAMP, small interior, Raw Bronze | W1003-R

TRESTLES, Wenge & Nickel-plated Brass | TR450-WNPB

COAT PEG, Raw Bronze | W1016-R

ABOVE:

BRONZE WALL LAMP, small exterior, Raw Bronze | W1004-R

NEXT PAGES:

BRONZE WALL LAMP, small interior, Polished Bronze | W1003-P

BRONZE WALL LAMP

COAT PEG

TRESTLES

[see P.108](#)

[see P.136](#)

[see P.142](#)





SMALL BRONZE WALL LAMP | W1003

PREVIOUS PAGES, LEFT & RIGHT:  
Polished Bronze | W1003-P

BRONZE WALL LAMP [see P.110](#)



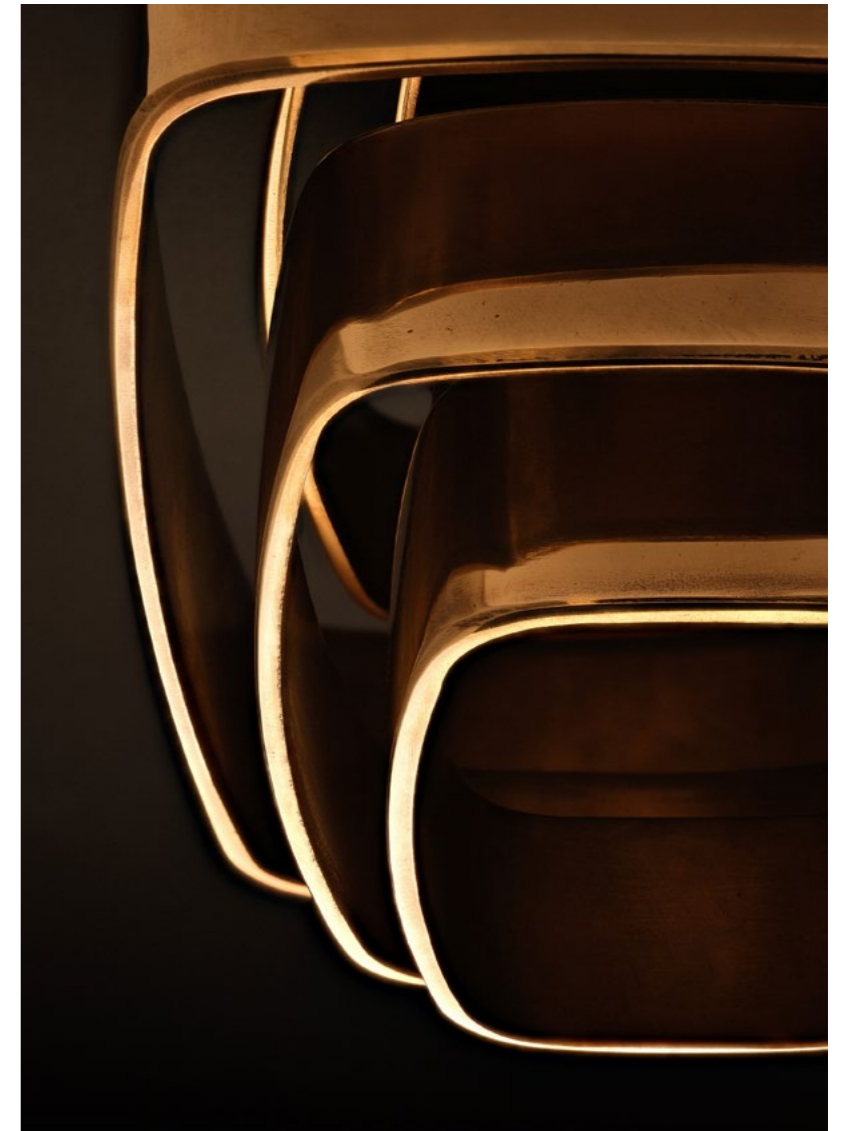

SMALL BRONZE WALL LAMP | W1003

LEFT & ABOVE: Polished Bronze | W1003-P

BRONZE WALL LAMP

[see P.108](#)





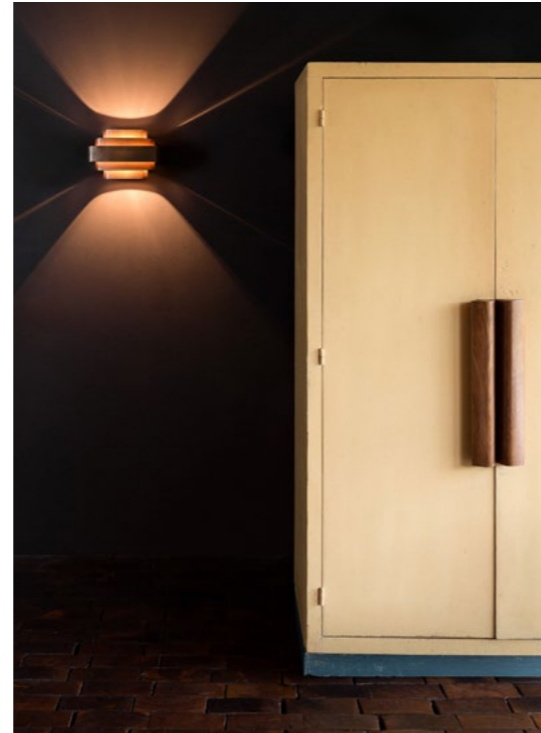

LARGE BRONZE WALL LAMP | W1001 & W1000

ABOVE: large & small, interior, Raw Bronze | W1001-R + W1003-R  
RIGHT & PREVIOUS PAGES: exterior, Raw Bronze | W1000-R

BRONZE WALL LAMP

[see P.108](#)

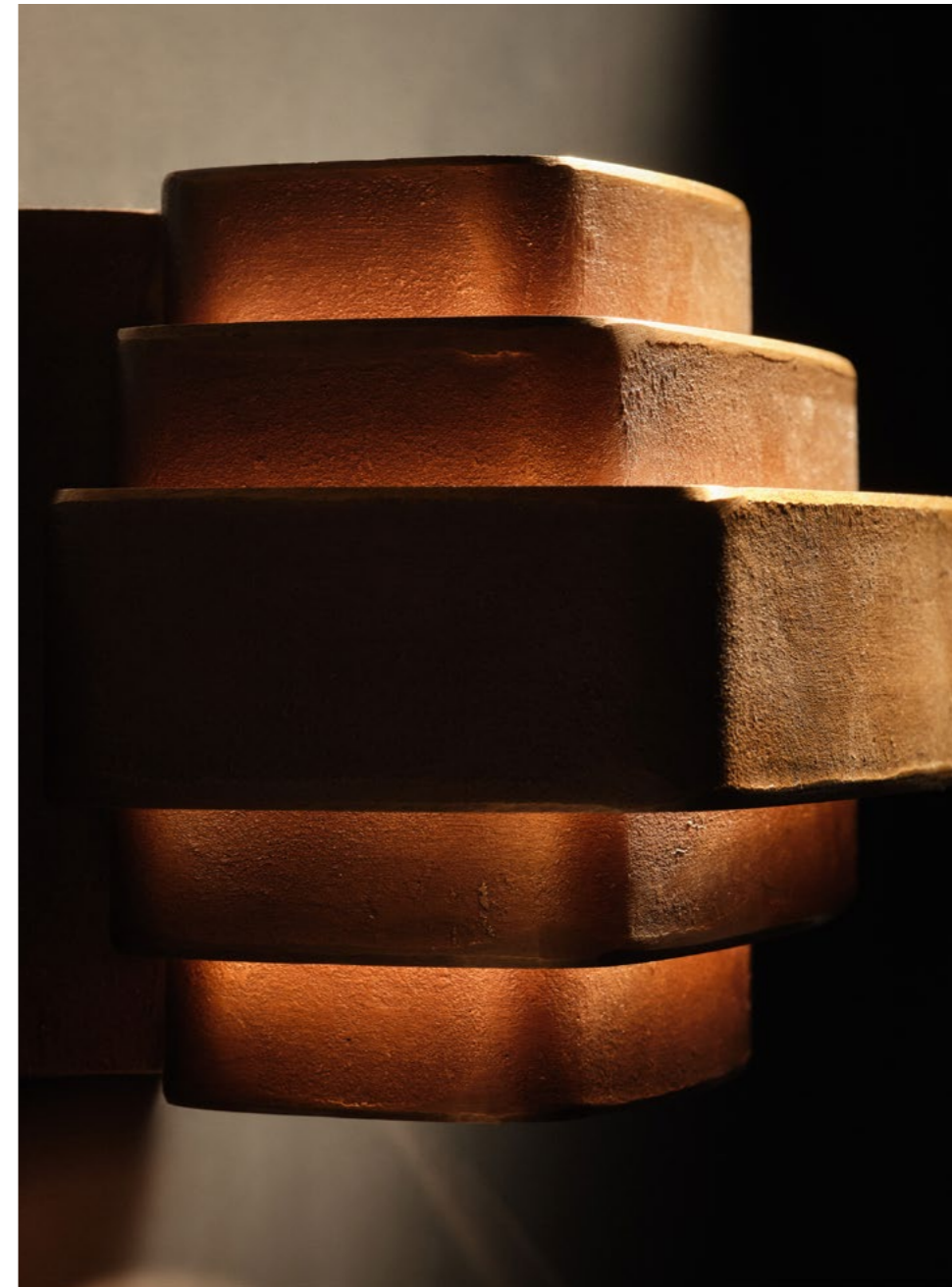

BRONZE WALL LAMP | W1000 & W1003

LEFT: Large exterior, Raw Bronze | W1000-R  
 ABOVE: Small exterior, Raw Bronze | W1003-R

BRONZE WALL LAMP

[see P.108](#)



BRONZE WALL LAMP | W1050

RIGHT & ABOVE: XL interior, Raw Bronze | W1050-R

BRONZE WALL LAMP

[see P.108](#)

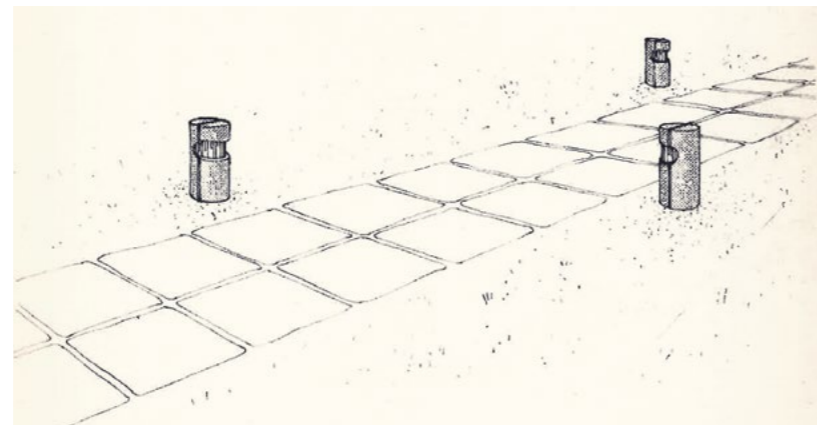

GARDEN LAMP | W1026

ABOVE: side & front views  
LEFT: Garden Lamp and archive drawing

GARDEN LAMP

see P.122



COAT PEGS | W1016

ABOVE: front view, Raw Bronze | W1016-R  
 RIGHT: Chrome-plated Bronze | W1016-CP

COAT PEG

[see P.136](#)





---

COAT PEGS, TRESTLES | W1016, TR450

ABOVE: Polished Bronze, side,  
3/4 and front views | W1016-P  
RIGHT: Coat Peg, Raw Bronze | W1016-R  
Trestles, Wenge and Brass, detail  
with tabletop | TR450-WPB

---

COAT PEG	<a href="#">see P.136</a>
TRESTLES	<a href="#">see P.142</a>

---





BUTTERFLY COAT RACKS | BCR

LEFT: Nickel-plated Brass & Movingui | BCR-NPB  
ABOVE: Polished Brass & Cocobolo | BCR-PB

BUTTERFLY COAT RACK

[see P.137](#)



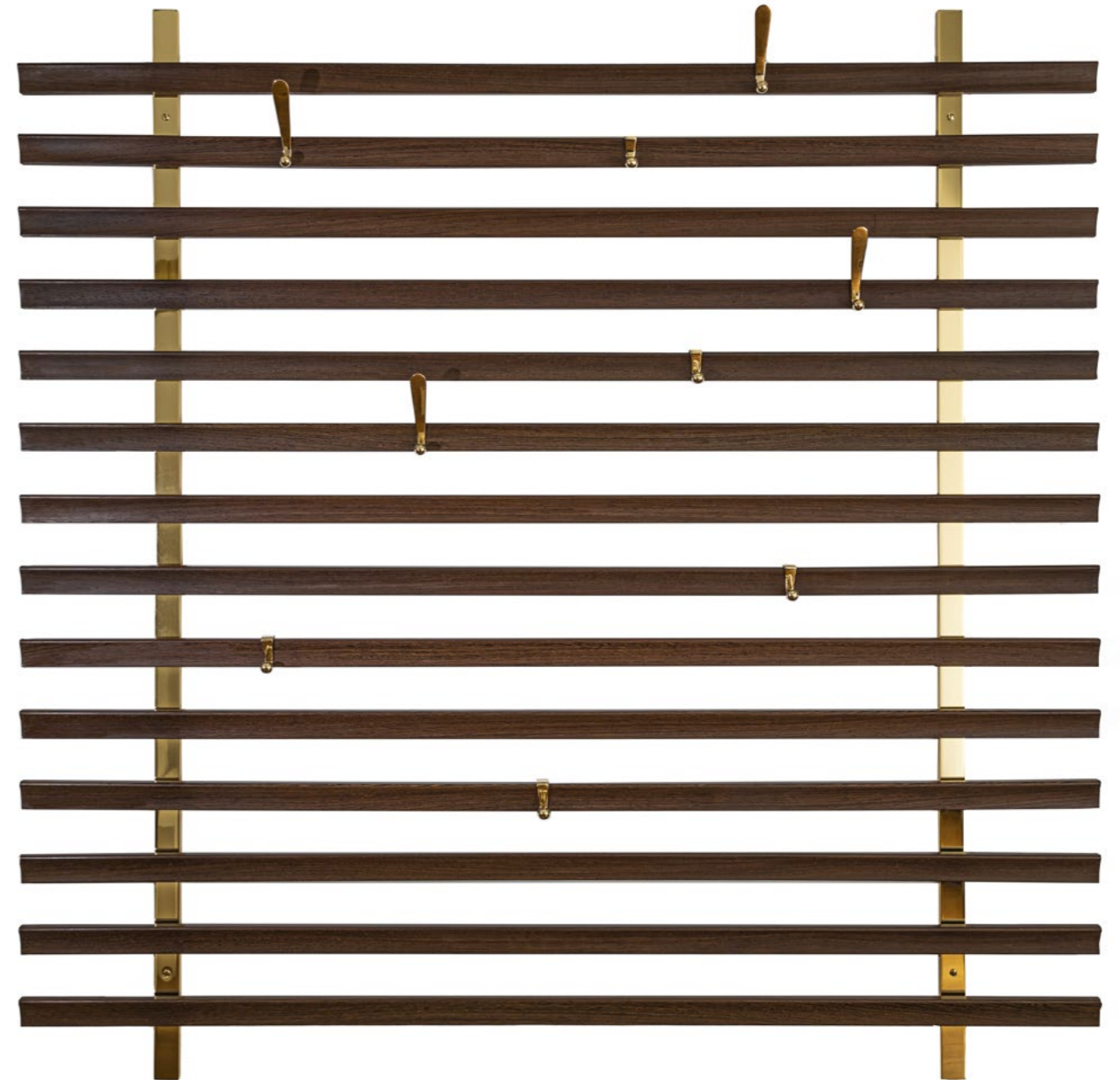

SLATTED COAT RACK | SCR1500

LEFT & RIGHT: front view, tailor-made furniture,  
Wenge & Polished Brass | SCR1500-WPB

SLATTED COAT RACK

[see P.138](#)



SLATTED COAT RACK | SCR2000

LEFT: front view, Oak & Nickel-plated Brass | SCR2000-ONPB

SLATTED COAT RACK [see P.138](#)

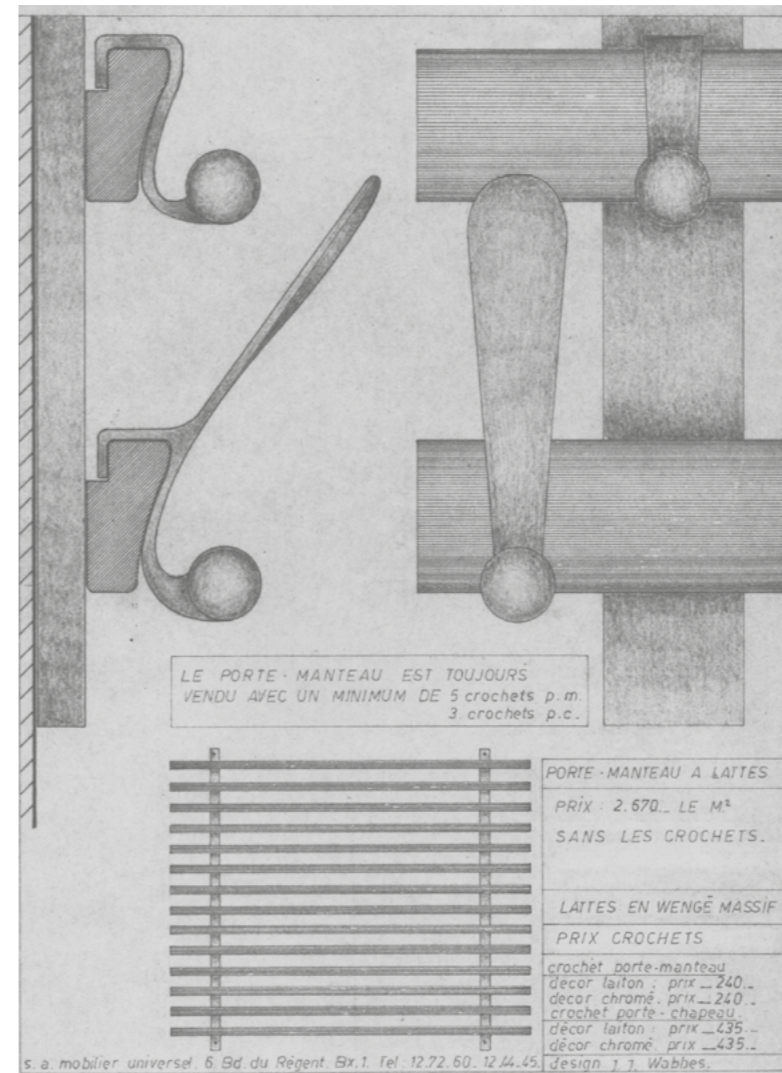
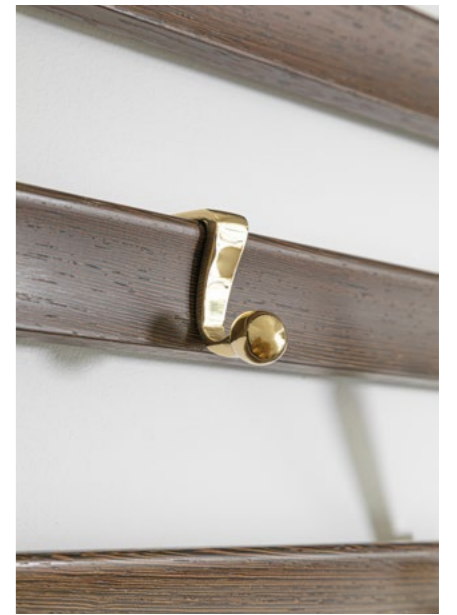

SLATTED COAT RACK

RIGHT: hooks details, Wenge & Polished Brass + Technical drawing

SLATTED COAT RACK [see P.138](#)





TRESTLES | TR450, TR650

PREVIOUS PAGES: Trestles, Wenge & Brass  
with Slate Tabletop | TR450-WPB  
LEFT [top]: Trestles, Wenge and Brass  
with Desk Tabletop | TR650-WPB  
LEFT [bottom]: Trestles with Tabletop –  
[detail] laminated shelf with solid  
wedge edge | TR450-WNPB  
ABOVE [left]: Wenge & Nickel-plated Brass,  
ABOVE [right]: Wenge & Brass | TR650-WPB

TRESTLES

see P.142

TRESTLES



TRESTLES | TR450

LEFT: Trestles, Wenge & Brass  
with Waxed slate tabletop, detail  
ABOVE: Trestles & tabletop | TR450-WPB

TRESTLES

see P.142



---

ACCESSORIES / TRINKET BOWL | W1022

LEFT: Polished Bronze, detail  
ABOVE: archive image | W1022-P

---

TRINKET BOWL

[see P.134](#)

---



FIRE ACCESSORIES / FIREDOGS | W1030

LEFT and ABOVE:  
Ironcast & Polished Bronze

FIREDOGS [see P.127](#)



FIRE ACCESSORIES / FIRE BELT | W1031

LEFT: front view Iron & Polished Bronze  
ABOVE: top view

FIRE BELT

[see P.126](#)





FIRE BASKET | SFB01

ABOVE: Small, Iron Cast

FIRE BASKET

[see P.128](#)



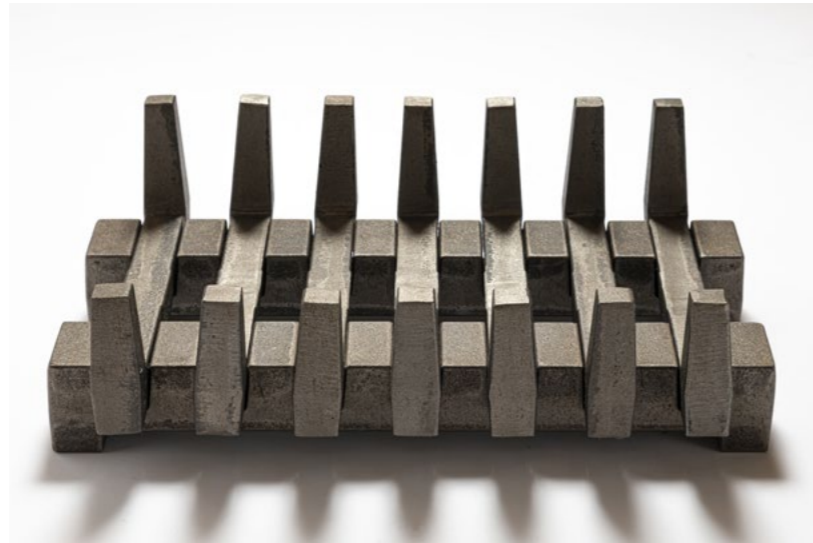

---

FIRE BASKET | SFB01, LFB02

ABOVE [top]: Small, Iron Cast  
ABOVE [bottom]: Large, Iron Cast

---

FIRE BASKET

[see P.128](#)

---

I.



II.

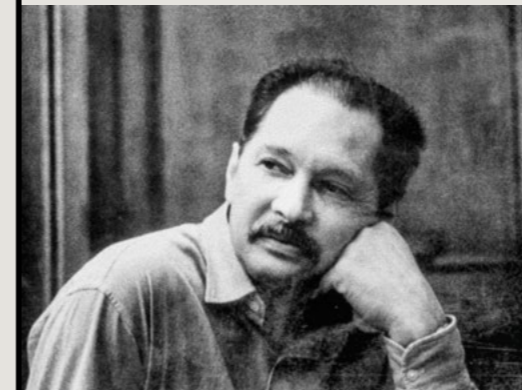

# HISTORY

## ESTABLISHED IN 1969 BY JULES WABBES

Jules Wabbes founded GENERAL DECORATION (GEDE) in 1969 in Brussels. The company has since then, for more than 50 years, manufactured and retailed metal accessories and furniture exclusively designed by Jules Wabbes.

Our set of elegant and functional objects, essential to any interior, was designed by the Belgian designer throughout his career. This collection was part of his general vision for designing interiors as a refined and coherent ensemble. The only thing that mattered to Jules Wabbes was the sincere expression of quality in every details.

The level of craftsmanship and the use of the very best materials are the genuine signature of Jules Wabbes. Each piece is handmade in metal - bronze, brass, iron, steel - and wood all materials favoured by Wabbes for their resistance and nobility.

We are still producing each of his objects using the exact same materials he used, crafted in small quantities by artisans in Belgium. Each GENERAL DECORATION metal object is then stamped to certify of its authenticity.

### FIGURES

I. Renée Wolf, *portrait de Jules Wabbes*, oil on canvas, 100 x 79 cm

II. Jules Wabbes, *portrait with a moustache*

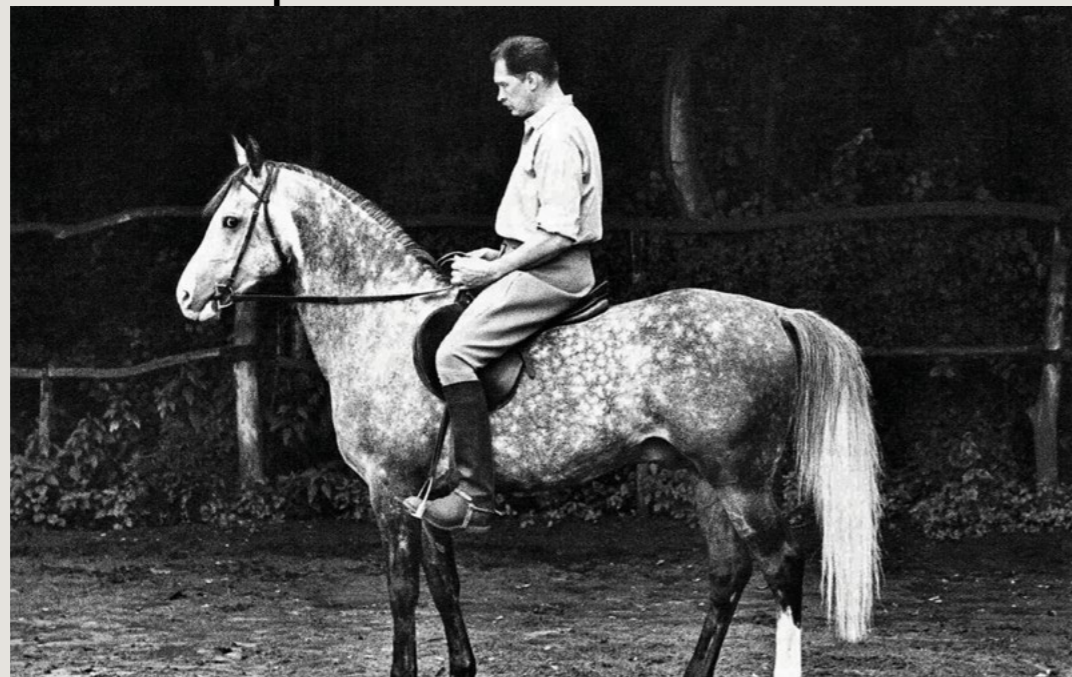

I.

### JULES WABBES

Jules Wabbes is one of the leading Belgian furniture designers and interior architects of the postwar period. He first opened an antique and decoration shop in Brussels before starting to create his own furnitures and objects.

He opened an office of industrial design to enlarge his project to architecture and office design. Therefore he associated with architects notably André Jacquain (until 1960). Among his large-scale works banks and office building such as the Foncolin Building, the Glaverbel quarters or La Générale de Banque and its strongroom. He was known for his office desks, tables and cabinets crafted from precious and exotic woods on elegant frames of stainless steel. His attention to every detail led him to create a collection of metal accessories to fit into these interiors.

He co-founded first successful company, Mobilier Universel, in 1957 that also produced American designers, as Wabbes travelled extensively to the US in that period. He eventually furnished the US embassies of London, Dakar and Rabat. A few years later, he was ousted from Mobilier Universel unwilling to compromise quality for profit.

II.



### FIGURES

- I. Jules Wabbes on his horse, Sky Banner, a thoroughbred Arab.  
II. Family of Jules Wabbes in 1971

He then founded GENERAL DECORATION in 1969 in order to manufacture and retail exclusively his metal accessories according to his own quality principles.

Wabbes was awarded several prizes, notably in 1957 and 1960 at the Milan Triennial.

### WABBES FAMILY HERITAGE

After the passing of Jules Wabbes, GENERAL DECORATION has never ceased to exist, for Jules Wabbes' spouse took over and had some objects produced while keeping all intellectual property.

In 2013, Vincent Colet antiquarian, expert and editor of objects and his wife, Caroline Bossuyt graduate of a design school (CAD)—together with the Wabbes family, and particularly with Marie Ferran-Wabbes, Jules Wabbes' daughter and art historian, decided to reinvigorate GENERAL DECORATION with the ideals and spirit of its beginnings.

### TIMELESS HERITAGE

Jules Wabbes remained inspired by its first vocation as an antiquarian in his classical approach to interior and architecture details. He was fascinated by designs that would resist through time. His creations are an expression of pure quality by use, and a mix, of excellent materials.

Today GENERAL DECORATION is committed to the same standards of excellence his founder expected. GENERAL DECORATION produces his objects, genuine pieces of timeless design, that are meant to last and be passed from one generation to the next.

### ORIGINAL DOCUMENTS, MATERIALS AND CRAFTSMANSHIPS

GENERAL DECORATION owns the exclusive licence to the original sketches and drawings of the celebrated Belgian designer in a catalogue of about 70 objects ranging from bathroom accessories through coat racks, table to wall lamps.

Each of our original objects produced today is therefore manufactured according to the initial product development plans defined by Jules Wabbes.

GENERAL DECORATION only works with a selected few artisans in Belgium that meet Jules Wabbes' attention to details and perfectionism.



I.

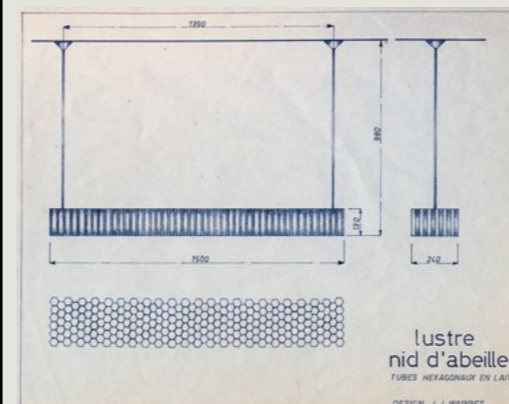

II.

### FIGURES

- I. Jules Wabbes presenting one of his lamps at the 11th Triennale of Milan, 1957  
II. Plan of the Honeycomb Ceiling Lamp

# PRODUCTS

## MATERIAL

BRONZE	
Bronze Wall Lamp	P.108
Hexagonal Table Lamp	P.118
Garden Lamp	P.122
Trinket Bowl	P.134
Coat Peg	P.136
Fire Belt	P.126
Firedogs	P.127
Fire Basket	P.128

BRASS	
Butterfly Coat Rack	P.137
Slatted Coat Rack	P.138
Trestles 450 / 650 / 850	P.142
Honeycomb Wall Lamp	P.144
Honeycomb Ceiling Lamp	P.146
Osaka Ceiling Lamp	P.150
Round Brass Pendant Lamp	P.152
Mini Wall Lamp	P.154
5-Band Wall Lamp	P.156
11-Band Wall Lamp	P.158

## CATEGORY

LIGHTING	
Honeycomb Wall Lamp	P.144
Honeycomb Ceiling Lamp	P.146
Mini Wall Lamp	P.154
Hexagonal Table Lamp	P.118
Bronze Wall Lamp	P.110
Osaka Ceiling Lamp	P.150
Round Brass Pendant Lamp	P.152
Garden Lamp	P.122
5-Band Wall Lamp	P.156
11-Band Wall Lamp	P.158

## COAT PEGS & COAT RACKS

Coat Peg	P.136
Butterfly Coat Rack	P.137
Slatted Coat Rack	P.138

## TRESTLES

Trestles 450 / 650 / 850	P.142
--------------------------	-------

## FIRE ACCESSORIES

Fire Belt	P.126
Firedogs	P.127
Fire Basket	P.128

## ACCESSORIES

Trinket Bowl	P.134
--------------	-------

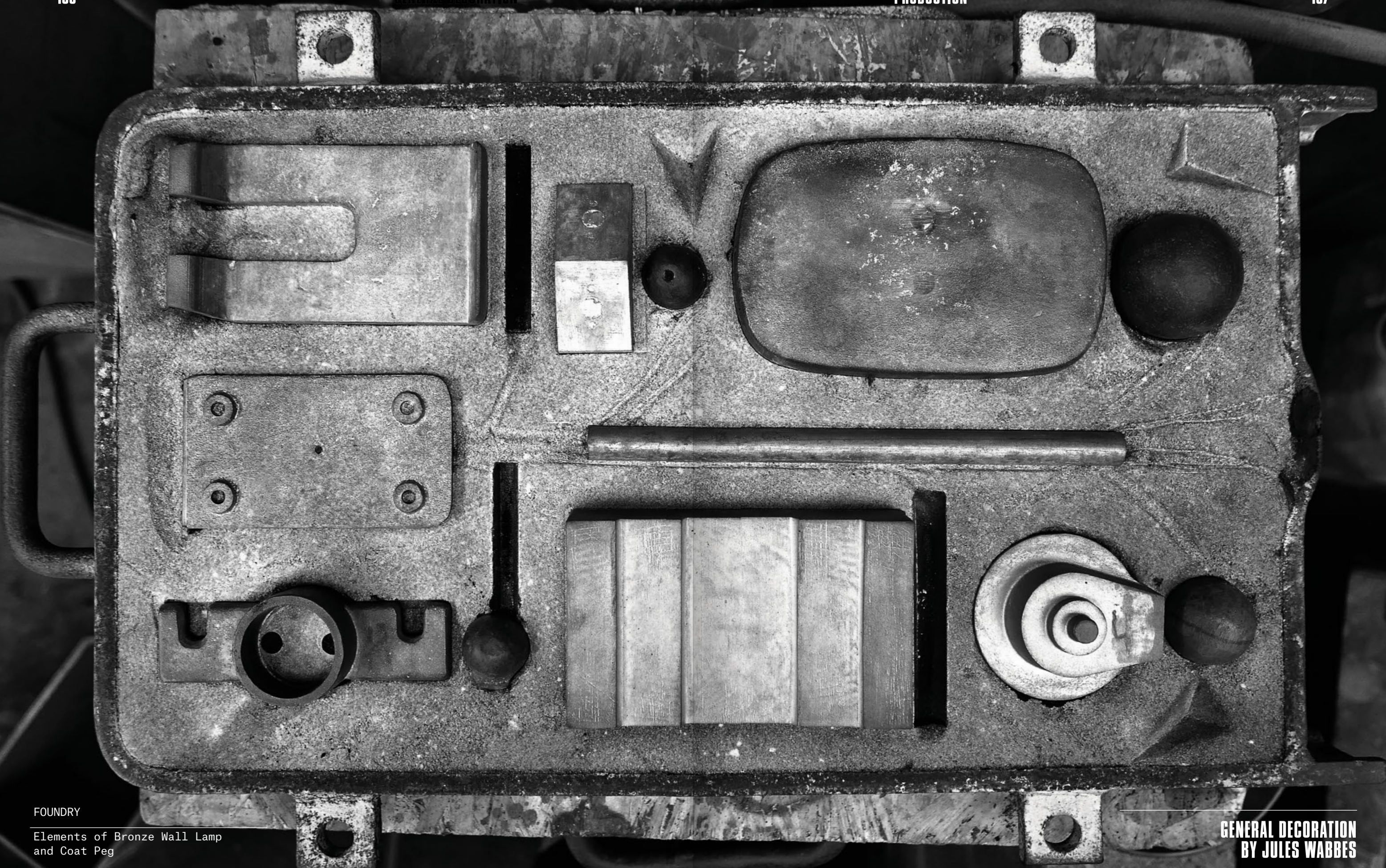

FOUNDRY  
Elements of Bronze Wall Lamp  
and Coat Peg

GENERAL DECORATION  
BY JULES WABBES

APPLIQUE BRONZE BRUT

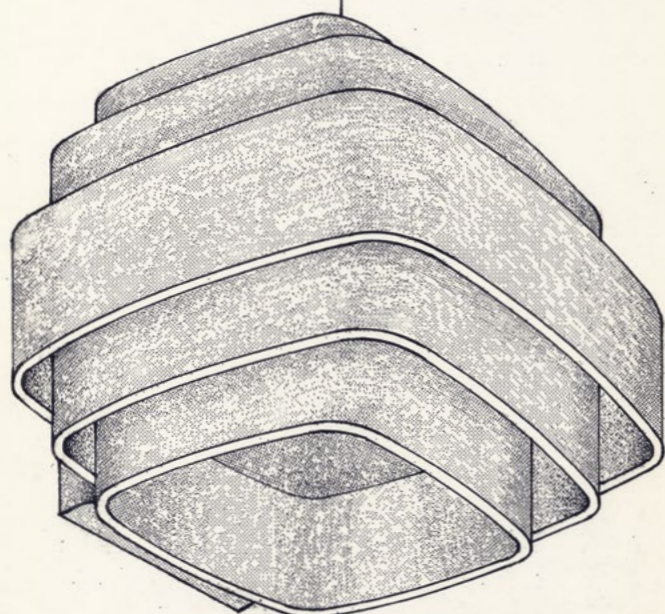

GENERAL DECORATION

RUE DE MIDDELBOURG 48. 1170 BRUXELLES TEL : 73.61.40

grand modèle : 18.000 ₣ (hors TVA)  
 petit modèle : 15.000 ₣ (hors TVA)  
 22 x 26 x 23  
 15,5 x 24 x 15,5

SMALL BRONZE WALL LAMP

Interior W1003 | Exterior W1004

This wall lamp was designed by Jules Wabbes and manufactured by GENERAL DECORATION from 1969. Made of five rings of cast bronze. Other models by the creator were designed in the same way but in brass. Wabbes often utilised a series of curved flat portions of different dimensions.

This lamp is suitable for indoor and outdoor use thanks to a system of glass which protects the bulb. The bronze takes a beautiful patina with time and weather.

1969



(Small Interior) FRONT  
 Length (L) 240 mm / 9.45"  
 Height (H) 163 mm / 6.40"



(Small Exterior) TOP  
 Depth (D) 148 mm / 5.80"



(Small Exterior) BOTTOM  
 Depth (D) 148 mm / 5.80"

TECHNICAL SPECS

NAME Small Bronze Wall Lamp  
 ORIGINAL DESIGN 1969  
 MATERIAL Bronze  
 DIMENSIONS  
 (L) 240 x (D) 148 x (H) 163 [mm]  
 (L) 9.45 x (D) 5.80 x (H) 6.40 ["]  
 WEIGHT  
 Small Exterior: 7.7 kg / 16.98 lbs  
 Small Interior: 7.0 kg / 15.50 lbs  
 FINISHES / PRODUCT REF.  
 Interior Raw Bronze | W1003-R  
 Exterior Raw Bronze | W1004-R  
 PRODUCTION / EDITION On Demand

LIFESTYLE SEE P. 52-71

GENERAL DECORATION  
 BY JULES WABBES

## LARGE INTERIOR BRONZE WALL LAMP

W1001



(Large Interior) FRONT

Length (L) ← 260 mm / 10.25"  
Height (H) | 205 mm / 8.00"



(Large Interior) TOP

Depth (D) ↘ 230 mm / 9.00"

### TECHNICAL SPECS

NAME Large Bronze Wall Lamp  
ORIGINAL DESIGN 1969  
MATERIAL Bronze  
DIMENSIONS  
(L) 260 × (D) 230 × (H) 205 [mm]  
(L) 10.25 × (D) 9.00 × (H) 8.00 ["]

WEIGHT  
Large Interior: 9.1 kg / 20.06 lbs

FINISHES / PRODUCT REF.  
Raw Bronze | W1001-R  
Polished Bronze | W1001-P

PRODUCTION / EDITION On Demand

**GENERAL DECORATION  
BY JULES WABBES**

LIFESTYLE SEE P. 52-71

## LARGE EXTERIOR BRONZE WALL LAMP

W1000



(Large Exterior) FRONT

Length (L) ← 265 mm / 10.25"  
Height (H) | 205 mm / 8.00"



(Large Exterior) TOP

Depth (D) ↘ 230 mm / 9.00"

### TECHNICAL SPECS

NAME Large Bronze Wall Lamp  
ORIGINAL DESIGN 1969  
MATERIAL Bronze  
DIMENSIONS  
(L) 265 × (D) 230 × (H) 205 [mm]  
(L) 10.25 × (D) 9.00 × (H) 8.00 ["]

WEIGHT  
Large Exterior: 9.6 kg / 21.16 lbs

FINISHES / PRODUCT REF.  
Raw Bronze | W1000-R

PRODUCTION / EDITION On Demand

**GENERAL DECORATION  
BY JULES WABBES**

LIFESTYLE SEE P. 52-71



**SMALL INTERIOR  
BRONZE WALL LAMP**

W1003



(Small Interior) FRONT  
 Length (L) ← 240 mm  
 Height (H) I 163 mm



(Small Interior) TOP  
 Depth (D) ↘ 148 mm

## TECHNICAL SPECS

NAME Small Bronze Wall Lamp  
 ORIGINAL DESIGN 1969  
 MATERIAL Bronze

DIMENSIONS  
 (L) 240 × (D) 148 × (H) 163 [mm]  
 (L) 9.45 × (D) 5.80 × (H) 6.40 ["]

WEIGHT  
 Small Interior: 7.0 kg / 15.50 lbs

FINISHES / PRODUCT REF.  
 Polished Bronze | W1003-P  
 Raw Bronze | W1003-R  
 Nickel-plated Bronze | W1003-NPB

PRODUCTION / EDITION On Demand

**GENERAL DECORATION  
BY JULES WABBES**

LIFESTYLE SEE P. 52-71

**LARGE INTERIOR  
BRONZE WALL LAMP**

W1001



(Large Interior) FRONT  
 Length (L) ← 265 mm  
 Height (H) I 205 mm

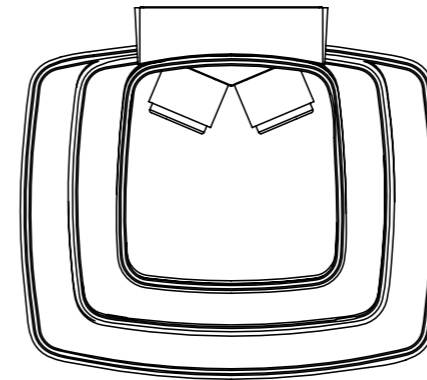

(Large Interior) TOP  
 Depth (D) ↘ 230 mm

## TECHNICAL SPECS

NAME Large Bronze Wall Lamp  
 ORIGINAL DESIGN 1969  
 MATERIAL Bronze

DIMENSIONS  
 (L) 265 × (D) 230 × (H) 205 [mm]  
 (L) 10.25 × (D) 9.00 × (H) 8.00 ["]

WEIGHT  
 Large Interior: 9.1 kg / 20.06 lbs

FINISHES / PRODUCT REF.  
 Polished Bronze | W1001-R  
 Raw Bronze | W1001-P  
 Nickel-plated Bronze | W1001-NPB

PRODUCTION / EDITION On Demand

**GENERAL DECORATION  
BY JULES WABBES**

LIFESTYLE SEE P. 52-71

**X-LARGE INTERIOR  
BRONZE WALL LAMP**

W1050



(X-Large Interior) FRONT

Length (L)    ← 320 mm / 12.60"  
Height (H)    | 270 mm / 10.63"



(X-Large Interior) TOP

Depth (D)    ↘ 250 mm / 9.85"

## TECHNICAL SPECS

NAME            X-Large Bronze Wall Lamp  
ORIGINAL DESIGN    1969  
MATERIAL            Bronze  
DIMENSIONS  
    (L) 320 × (D) 250 × (H) 270 [mm]  
    (L) 12.60 × (D) 9.85 × (H) 10.63 ["]

## WEIGHT

Large Interior: 13.5 kg / 29.76 lbs

## FINISHES / PRODUCT REF.

Raw Bronze | W1050-R  
Polished Bronze | W1050-P

PRODUCTION / EDITION    On Demand

**GENERAL DECORATION  
BY JULES WABBES**

LIFESTYLE SEE P. 52-71

**X-LARGE EXTERIOR  
BRONZE WALL LAMP**

W1051



(X-Large Exterior) FRONT

Length (L)    ← 320 mm / 12.60"  
Height (H)    | 270 mm / 10.63"

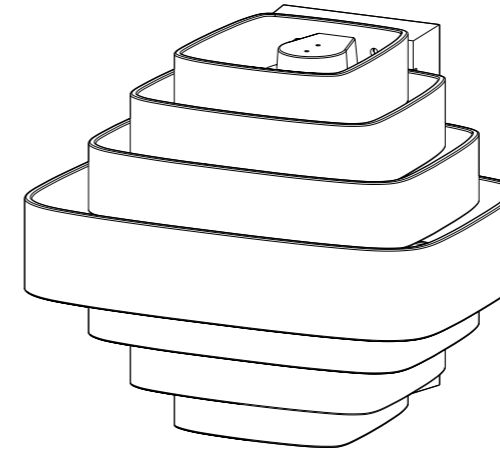

(X-Large Exterior) TOP

Depth (D)    ↘ 250 mm / 9.85"

## TECHNICAL SPECS

NAME            X-Large Bronze Wall Lamp  
ORIGINAL DESIGN    1969  
MATERIAL            Bronze  
DIMENSIONS  
    (L) 320 × (D) 250 × (H) 270 [mm]  
    (L) 12.60 × (D) 9.85 × (H) 10.63 ["]

## WEIGHT

Large Exterior: 13.5 kg / 29.76 lbs

## FINISHES / PRODUCT REF.

Raw Bronze | W1051-R

PRODUCTION / EDITION    On Demand

**GENERAL DECORATION  
BY JULES WABBES**

LIFESTYLE SEE P. 52-71



## FOUNDRY

Bronze Wall Lamp: A ring (central part) being removed from the core casting box

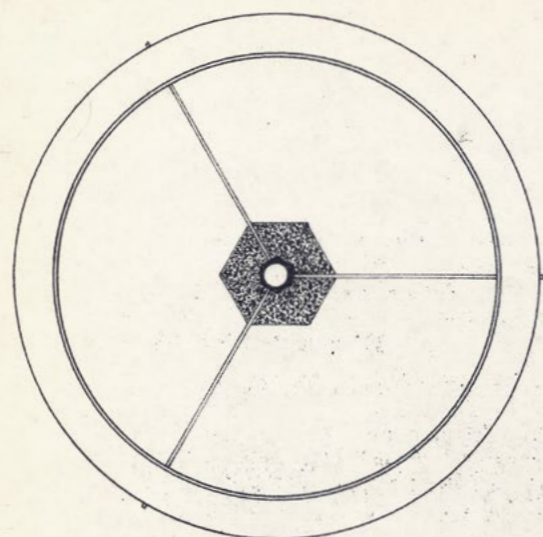

**GENERAL DECORATION  
BY JULES WABES**

**LAMPE**

DESIGN J. J. WABBES

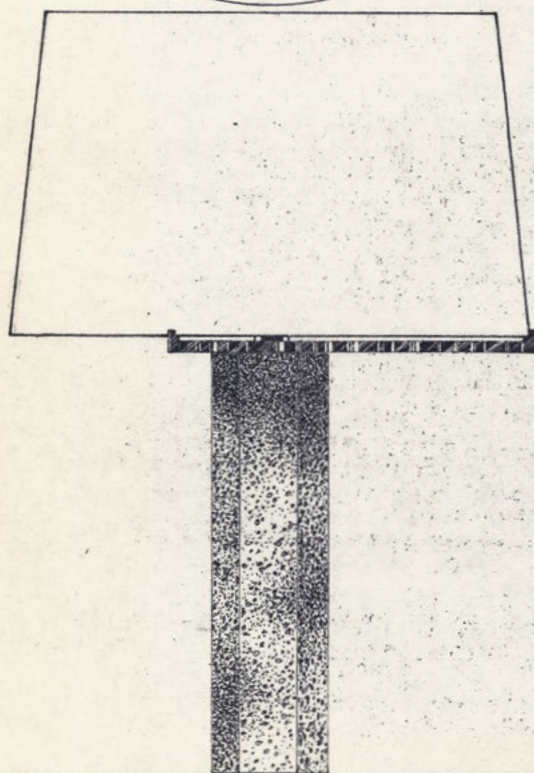
**s. a. mobilier universel**

6 BOULEVARD DU REGENT 1000 BX

TEL : 12.72.60 12.44.45

**HEXAGONAL TABLE LAMP****HEXAGONAL TABLE LAMP**

W1005

Table lamp, hexagonal raw bronze leg, paper shade. This lamp was created in the late 60's, inspired by a stone model of the Dunbar collection designed by Edward J. Wormley in 1959.

Jules Wabbes reinterpreted this classic model. The lampshade is simply held by three notched metal rods. The first copies made of travertine were produced by Mobilier Universel. They were later made of metal and distributed by GENERAL DECORATION in 1969.

**1968**

(Polished Bronze) FRONT  
 Diameter (D) 460 mm  
 Height (H) 690 mm



(Raw Bronze) FRONT  
 Diameter (D) 460 mm  
 Height (H) 690 mm

## TECHNICAL SPECS

NAME Hexagonal Table Lamp  
 ORIGINAL DESIGN 1968  
 MATERIAL Bronze

DIMENSIONS (D) 460 × (H) 690 [mm]  
 (D) 18.00 × (H) 27.20 ["]  
 WEIGHT 8.6 kg / 18.96 lbs

FINISHES / PRODUCT REF.  
 Raw Bronze | W1005-R  
 Polished Bronze | W1005-P  
 Patinated Bronze | W1005-PT  
 Burgundy | W1005-B

PRODUCTION / EDITION On Demand

LIFESTYLE SEE P. 38-51

**GENERAL DECORATION  
 BY JULES WABBES**

## HEXAGONAL TABLE LAMP

50th ANNIVERSARY  
EDITION 1969-2019

(Belgian Marble, Bronze) FRONT  
 Diameter (D) ↔ 460 mm / 18.00"  
 Height (H) | 690 mm / 27.20"

## TECHNICAL SPECS

NAME Hexagonal Table Lamp  
 ORIGINAL DESIGN 1968  
 MATERIAL Marble, Bronze  
 DIMENSIONS (D) 460 × (H) 690 [mm]  
 (D) 18.00 × (H) 27.20 ["]  
 WEIGHT 8.6 kg / 18.96 lbs  
 FINISHES / PRODUCT REF.  
 "Gris des Ardennes" Belgian Marble,  
 Bronze | W1005-EDL  
 LIMITED EDITION 50 pieces

GENERAL DECORATION  
BY JULES WABBES

LIFESTYLE SEE P. 38-51

SMALL HEXAGONAL  
TABLE LAMP

(Polished Bronze) FRONT  
 Diameter (D) ↔ 333 mm / 13.10"  
 Height (H) | 508 mm / 20.00"



(Raw Bronze) FRONT  
 Diameter (D) ↘ 333 mm / 13.10"  
 Height (H) | 508 mm / 20.00"

## TECHNICAL SPECS

NAME Small Hexagonal Table Lamp  
 ORIGINAL DESIGN 1968  
 MATERIAL Bronze  
 DIMENSIONS (D) 333 × (H) 508 [mm]  
 (D) 13.10 × (H) 20.00 ["]  
 WEIGHT 5.0 kg / 11.02 lbs  
 FINISHES / PRODUCT REF.  
 Polished Bronze | W1025-P  
 Raw Bronze | W1025-R  
 Patinated Bronze | W1025-PT  
 Burgundy | W1025-B  
 PRODUCTION / EDITION On Demand

LIFESTYLE SEE P. 38-51

GENERAL DECORATION  
BY JULES WABBES

## SPOT pour JARDIN

bronze brut

## NOTE pour l'électricien

- 1) Elever les 4 grosses vis et faire alors le simple raccordement électrique.
- 2) Pour le remplacement de la lampe défaire les deux petits vis sur les arrêtes de côté et soulever le chapeau en bronze. - Il n'est pas nécessaire pour le changement de lampe, d'ouvrir le boîtier de raccordement (c-à-d les 4 grosses vis)

(N.B.) en désserrant légèrement les 2 vis sur les arrêtes de côté, vous pouvez aisément orienter le chapeau.

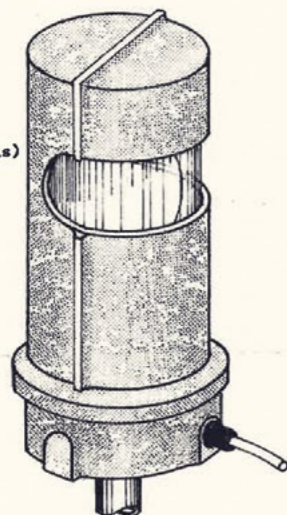

niveau de placement

le spot se place soit dans la maçonnerie, soit dans la terre avec un piquet.

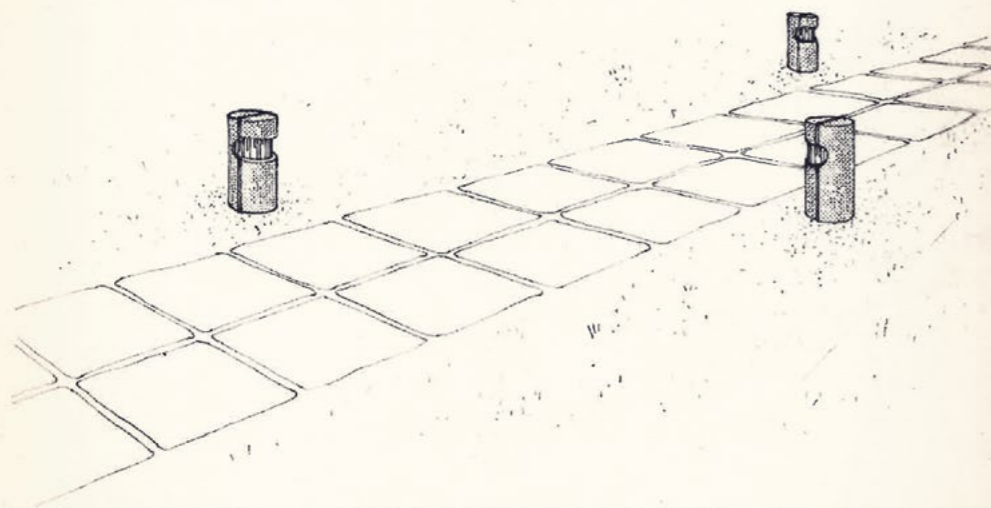

GENERAL DECORATION

RUE DE MIDDELBOURG 48. 1170 BRUXELLES

prix : 6,500 € (hors TVA)

TE : 073.61.40

## GARDEN LAMP

## GARDEN LAMP



(Raw Bronze) FRONT  
 Diameter (D) 125 mm / 4.90"  
 Height (H) 256 mm / 10.08"



(Raw Bronze) TOP  
 Diameter (D) 125 mm / 4.90"  
 Height (H) 256 mm / 10.08"

The Garden Spot is a cylindrical piece of cast raw bronze. This lamp is designed to blend discreetly into nature while gaining a natural patina over time very alike the one of a bark of a tree.

This lamp has been endorsed and used by leading landscape architects and designers such as Jacques Wirtz and Jean-Noël Capart.

GENERAL DECORATION has manufactured this garden element since its creation in 1969.

1969

## TECHNICAL SPECS

NAME Garden Lamp  
 ORIGINAL DESIGN 1969  
 MATERIAL Bronze

DIMENSIONS (H) 256 x (D) 125 [mm]  
 (H) 10.08 x (D) 4.90 ["]  
 WEIGHT 5.2 kg / 11.46 lbs

FINISHES / PRODUCT REF.  
 Raw Bronze | W1026-R

PRODUCTION / EDITION On Demand

LIFESTYLE SEE P. 72-73

GENERAL DECORATION  
 BY JULES WABBES



## FIRE BELT

The Fire Belt is handmade in iron and polished bronze, both materials preferred by Wabbes for their particular patina once regularly used and blackened by fire.

This ingenious model describes one elegant curve around the fireplace. Its shape is directly inspired by the one of a regular leather belt.

Its design allows the piece to adjust itself in width, by simply gliding its two parts through the two buckles.

This model was created in 1969 for GENERAL DECORATION.

1969



(Iron / Polished Bronze) FRONT  
 Length (L) ← 280 mm / 11.00"  
 Height (H) | 75 mm / 3.00"



(Iron / Polished Bronze) TOP  
 Width (W) ↘ 260-400 mm  
 10.25-15.75"

## TECHNICAL SPECS

NAME Fire Belt  
 ORIGINAL DESIGN 1969  
 MATERIAL Iron & Bronze

## DIMENSIONS

(L) 280 × (W) 260-400 × (H) 75 [mm]  
 (L) 11 × (W) 10.25-15.75 × (H) 3 ["]  
 WEIGHT 5,4 kg / 11.91 lbs

## FINISHES / PRODUCT REF.

Iron, Polished Bronze | W1031

## PRODUCTION / EDITION

On Demand

**GENERAL DECORATION  
 BY JULES WABBES**

LIFESTYLE SEE P. 96-97

## FIREDOGS



(Iron Cast / Polished Bronze) FRONT  
 Length (L) ← 420 mm / 16.50"  
 Height (H) | 130 mm / 5.10"



(Iron Cast / Polished Bronze) LEFT  
 Width (W) ↘ 195 mm / 7.70"

## TECHNICAL SPECS

NAME Firedogs  
 ORIGINAL DESIGN 1967  
 MATERIAL Iron & Bronze

## DIMENSIONS

(L) 420 × (W) 195 × (H) 130 [mm]  
 (L) 16.50 × (W) 7.70 × (H) 5.10 ["]  
 WEIGHT 21 kg / 46.30 lbs (each)

## FINISHES / PRODUCT REF.

Iron, Polished Bronze | W1030

## PRODUCTION / EDITION

On Demand

**GENERAL DECORATION  
 BY JULES WABBES**

LIFESTYLE SEE P. 94-95

The Firedogs are handmade in cast iron and bronze, both materials that gain a beautiful patina once used and blackened by fire.

These pieces were first conceived for Francois Installé's private living room during his entire home planning by Jules Wabbes in Braschaat between 1966 and 1967.

This model evokes giant bones, like the ones of a dinosaur or a mythical creature. Its shape intends to hold logs above the hearth to amplify the circulation of air and increase the fire strength.

GENERAL DECORATION has manufactured these elements since 1969.

1967



## SMALL FIRE BASKET

These andirons or firedogs were conceived like a basket or a grid in cast iron. They were designed for Wabbes' new house after his wedding in 1960. Indeed, the chimneys of his modern house were smaller than the traditional ones. Jules Wabbes needed to create something new to take advantage of the fireplace.

These andirons are very efficient for cradling the logs and allowing air to circulate. Enjoy a nice, warm wood fire at home again, in a safe way as the logs will securely and slowly burn.

You will keep them forever.  
No maintenance required.  
Natural patina.

1960 - 1965



(Raw Bronze)	FRONT
Length (L)	← 445 mm
Width (W)	I 295 mm

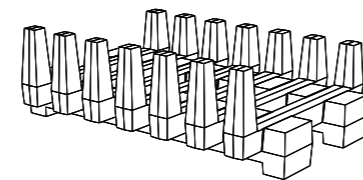

(Small Fire Basket)	LEFT
Height (H)	I 120 mm (front) 140 mm (back)

## TECHNICAL SPECS

NAME Small Fire Basket  
ORIGINAL DESIGN 1960 - 1965  
MATERIAL Bronze

## DIMENSIONS

(L) 445 × (W) 295 × (H) 140 [mm]  
(L) 17.50 × (W) 11.60 × (H) 5.50 ["]  
WEIGHT 30 kg / 66.14 lbs

## FINISHES / PRODUCT REF.

Iron Cast | SFB01

## PRODUCTION / EDITION

On Demand

**GENERAL DECORATION  
BY JULES WABBES**

LIFESTYLE SEE P. 98-100

## LARGE FIRE BASKET

1960 - 1965



(Raw Bronze)	FRONT
Length (L)	← 755 mm
Width (W)	I 450 mm

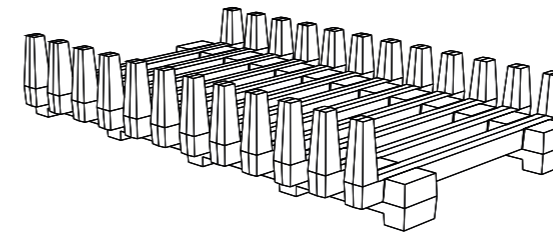

(Large Fire Basket)	LEFT
Height (H)	I 120 mm (front) 140 mm (back)

## TECHNICAL SPECS

NAME Large Fire Basket  
ORIGINAL DESIGN 1960 - 1965  
MATERIAL Bronze

## DIMENSIONS

(L) 755 × (W) 450 × (H) 140 [mm]  
(L) 29.75 × (W) 17.70 × (H) 5.50 ["]  
WEIGHT 60.0 kg / 132.28 lbs

## FINISHES / PRODUCT REF.

Iron Cast | LFB02

## PRODUCTION / EDITION

On Demand

**GENERAL DECORATION  
BY JULES WABBES**

LIFESTYLE SEE P. 98-100



BRONZE WALL LAMP (LEFT) & COAT PEG (RIGHT)  
Final polishing of bronze







3009,

**CENDRIER** bronze brut

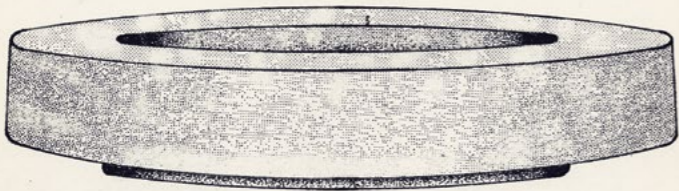
---



---

CENDRIER GRAND MODELE  MOYEN 

---

**GENERAL DECORATION**  
RUE DE MIDDELBOURG 48. 1170 BRUXELLES TEL : 73.61.40



(Polished Bronze)	FRONT
Diameter (D)	210 mm
Height (H)	48 mm



(Raw Bronze)	TOP
Diameter (D)	210 mm
Height (H)	48 mm

**TRINKET BOWL**

Model developed in the early days of General Decoration in 1969.

Jules Wabbes thought an ashtray would spoil a table. He thus created this timeless object with rounded lines in rough or polished bronze.

In the 70's, smoking was everywhere in life: in offices, waiting rooms, meeting rooms, restaurants. Things have changed today, but this object still keeps its place on a table or in an office, not so much as an ashtray rather as a stylish piece of furniture to leave paperclips or some small precious items.

1969

TECHNICAL SPECS

NAME	Trinket Bowl
ORIGINAL DESIGN	1969
MATERIAL	Bronze

DIMENSIONS

(D) 210 × (H) 48 [mm]  
(D) 8.25 × (H) 1.90 ["]

WEIGHT

4.0 kg / 8.82 lbs

FINISHES / PRODUCT REF.

Polished Bronze | W1022-P  
Raw Bronze | W1022-R

PRODUCTION / EDITION

On Demand

LIFESTYLE SEE P. 90-91

**GENERAL DECORATION  
BY JULES WABBES**

## COAT PEG

This bronze coat peg was conceived like a sculpture. Two hooks are placed on each side of a slightly concave oval.

Designed circa 1969 and edited by GENERAL DECORATION, this original creation is of an exceptional beauty. Designers rarely use noble materials, and generous rounded shapes to design a coat peg. Jules Wabbes stands out again with this piece of work.

Multiple copies of this model decorated the vaults room of the former Générale de Banque in Brussels.

1969

## TECHNICAL SPECS

NAME	Coat Peg
ORIGINAL DESIGN	1969
MATERIAL	Bronze

## DIMENSIONS

(L) 150 × (D) 82 × (H) 170 [mm]
(L) 5.90 × (D) 3.30 × (H) 6.70 ["]
WEIGHT 4.8 kg / 10.58 lbs

## FINISHES / PRODUCT REF.

Chrome-plated Bronze   W1016-C
Polished Bronze   W1016-P
Raw Bronze   W1016-R

PRODUCTION / EDITION	On Demand
----------------------	-----------

**GENERAL DECORATION  
BY JULES WABBES**

## COAT PEGS



(Chrome-plated Bronze)	FRONT
Length (L)	↔ 150 mm
Height (H)	⌋ 170 mm



(Polished Bronze)	LEFT
Depth (D)	↘ 82 mm



(Raw Bronze)	RIGHT
Depth (D)	↘ 82 mm

LIFESTYLE SEE P. 74-77

## BUTTERFLY COAT RACKS



(Nickel-plated Brass / Movingui)	FRONT
Length (L)	↔ max 405 mm
Height (H)	⌋ 400 mm



(Nickel-plated Brass / Movingui)	FRONT
Length (L)	↔ max 405 mm
Height (H)	⌋ 400 mm

LIFESTYLE SEE P. 78-79

## BUTTERFLY COAT RACK

The Butterfly Coat Rack is made of a pair of mobile brass hooks and a plain exotic wood block - either in Movingui and Nickel-plated Brass or Cocobolo and Polished Brass.

This coat rack was first conceived to support four clothes and two hats. Today, the upper part can be used to hang different types of garments without deforming them.

Both models have been handmade with the same level of craftsmanship and material quality as those recently found in Wabbes' family attic.

It is the first time this piece is being manufactured since its conception, making it a rarity and an exclusivity of GENERAL DECORATION.

1960

## TECHNICAL SPECS

NAME	Butterfly Coat Rack
ORIGINAL DESIGN	1960
MATERIAL	Wood & Brass

## DIMENSIONS

(L) 400 × (D) 80 × (H) 335 [mm]
(L) 15.95 × (D) 8.25 × (H) 1.90 ["]
WEIGHT 1.8 kg / 8.82 lbs

## FINISHES / PRODUCT REF.

Polished Brass, Cocobolo   BCR-PB
Nickel-plated Brass, Movingui   BCR-NPB

PRODUCTION / EDITION	On Demand
----------------------	-----------

**GENERAL DECORATION  
BY JULES WABBES**

## SLATTED COAT RACK

The slatted coat rack was created quite early in Jules Wabbes' design career, and probably before 1958. A photography of such a coat rack shows it was installed in the Foncolin, a large office building in Brussels, fully designed and furnished by Wabbes and his collaborators from 1954 to 1958. Jules Wabbes decided to prominently display the coat rack, therefore the coats and hats hung there, instead of hiding the garments in a cupboard. Wabbes' choice to do so was not a surprise, rather more of a coherent and radical principle found in his furniture design to make every part visible like the drawer slides of the desks and the joints of his slatted furniture. The coat rack reminds of a mechanical blind, a screen, a Japanese partition. The movable metallic hooks dance like notes on a music sheet, letting one create a very nice rhythm with the different hooks. This coat rack was originally sold by the meter: it is still the case today. You can decide to entirely cover the wall of your entrance hall or your cloakroom, like in Wabbes' mansion where the rack covers the wall all the way, even above the door.

1960

### TECHNICAL SPECS

NAME Slatted Coat Rack  
ORIGINAL DESIGN 1960  
MATERIAL Wood & Brass

DIMENSIONS  
(L) 1500 × (H) 1800 × (W) 90 [mm]  
(L) 59.00 × (H) 70.90 × (W) 3.50 ["]  
WEIGHT 21 kg / 46.30 lbs

FINISHES / PRODUCT REF.  
Wenge, Nickel-plated Brass | SCR-1500-WNPB  
Wenge, Polished Brass | SCR-1500-WPB  
Oak, Nickel-plated Brass | SCR-1500-ONPB  
Oak, Polished-Brass | SCR-1500-OPB

PRODUCTION / EDITION On Demand

**GENERAL DECORATION  
BY JULES WABBES**

## SLATTED COAT RACK 1500 x 1800



(Wenge) FRONT

Length (L) 1500 mm  
Height (H) 1800 mm

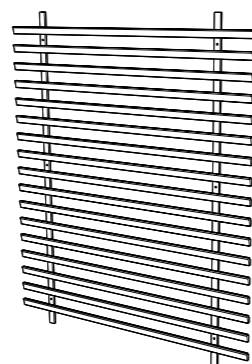

(Small Slatted Coat Rack) RIGHT

Length (L) 1500 mm  
Height (H) 1800 mm

LIFESTYLE SEE P. 80-83

## SLATTED COAT RACK 2000 x 1800



(Oak) FRONT

Length (L) 2000 mm  
Height (H) 1800 mm

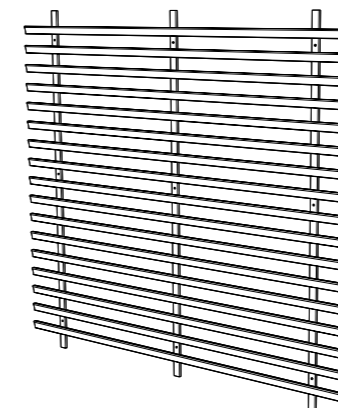

(Large Slatted Coat Rack) RIGHT

Length (L) 2000 mm  
Height (H) 1800 mm

LIFESTYLE SEE P. 80-83

## SLATTED COAT RACK

1960

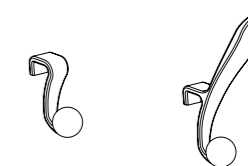

### SHORT HOOK

DIMENSIONS (H) 52 × (W) 40 mm  
(H) 2.00 × (W) 1.58 ["]  
WEIGHT 0.06 kg / 0.13 lbs

FINISHES / PRODUCT REF.  
Polished Brass | W1032-PB  
Nickel-plated Brass | W1032-NPB

### LONG HOOK

DIMENSIONS (H) 118 × (W) 76 mm  
(H) 4.65 × (W) 2.97 ["]  
WEIGHT 0.10 kg / 0.22 lbs

FINISHES / PRODUCT REF.  
Polished Brass | W1033-PB  
Nickel-plated Brass | W1033-NPB

### TECHNICAL SPECS

NAME Slatted Coat Rack  
ORIGINAL DESIGN 1960  
MATERIAL Wood & Brass

DIMENSIONS  
(L) 2000 × (W) 1800 × (W) 90 [mm]  
(L) 78.75 × (H) 70.90 × (W) 3.50 ["]  
WEIGHT 28 kg / 61.73 lbs

FINISHES / PRODUCT REF.  
Wenge, Nickel-plated Brass | SCR-2000-WNPB  
Wenge, Polished Brass | SCR-2000-WPB  
Oak, Nickel-plated Brass | SCR-2000-ONPB  
Oak, Polished-Brass | SCR-2000-OPB

PRODUCTION / EDITION On Demand

**GENERAL DECORATION  
BY JULES WABBES**



ROUND PENDANT BRASS  
 Polishing rings



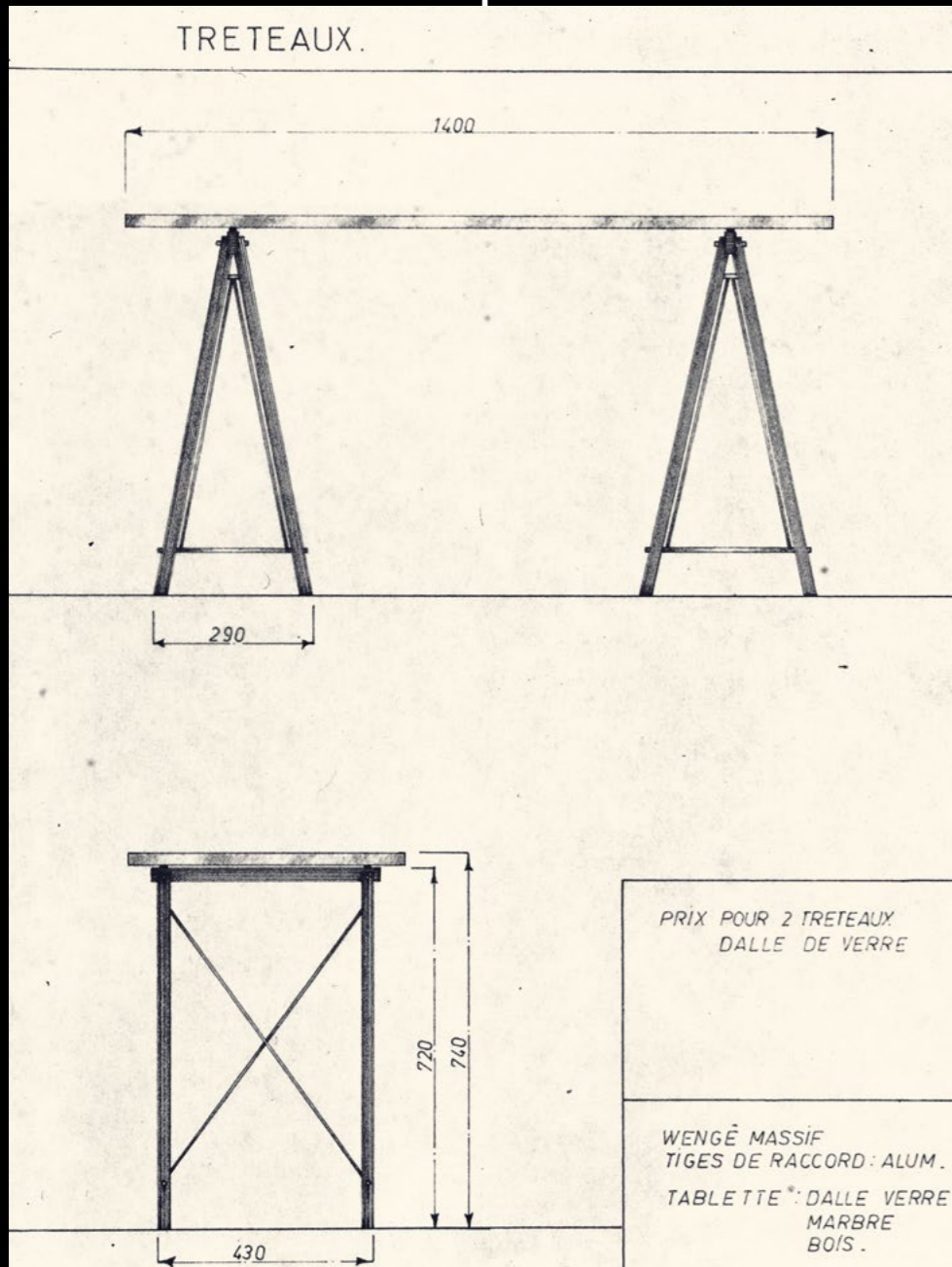

TRESTLES



(Wenge & Nickel-plated Brass  
Wenge & Brass) LEFT

Length (L)	↔	450 mm
Height (H)		720 mm
Length (L)	↔	650 mm
Height (H)		720 mm



(Wenge & Brass) LEFT

Width (W)	↘	292 mm
-----------	---	--------

THE TABLETOP IS CUSTOM MADE, CONTACT US FOR FURTHER INFORMATION AND ESTIMATE.

LIFESTYLE SEE P. 84-89

This pair of trestles was created before 1958 when mentioned in a bill.

The trestles are in wood and brass, assembled with special snake-eye screws. Very elegant and delicate, they are nonetheless very resistant and built like a small piece of architecture.

They are designed to support a wood, a marble or a glass shelf.

1953

TECHNICAL SPECS

NAME	Trestles
ORIGINAL DESIGN	1953
MATERIAL	Wenge & Brass

DIMENSIONS / WEIGHT

(L) 450 × (W) 292 × (H) 720 [mm]
(L) 17.70 × (W) 11.50 × (H) 28.35 ["]
3.1 kg / 6.83 lbs

DIMENSIONS / WEIGHT

(L) 650 × (W) 292 × (H) 720 [mm]
(L) 25.60 × (W) 11.50 × (H) 28.35 ["]
3.3 kg / 7.28 lbs

DIMENSIONS / WEIGHT

(L) 850 × (W) 292 × (H) 720 [mm]
(L) 33.45 × (W) 11.50 × (H) 28.35 ["]
3.5 kg / 7.72 lbs

FINISHES / PRODUCT REF.

Wenge, Nickel-plated Brass	TR-WNPB
Wenge, Polished Brass	TR-WPB
Oak, Nickel-plated Brass	TR-ONPB
Oak, Polished Brass	TR-OPB

PRODUCTION / EDITION

On Demand
-----------

GENERAL DECORATION  
BY JULES WABBES





## HONEYCOMB WALL LAMP

Royal Naval apartments Godetia,  
1965 (Photo: Henri Kessels)



(Nickel-plated Brass) FRONT  
Depth (W) — 254 mm  
Height (H) I 250 mm

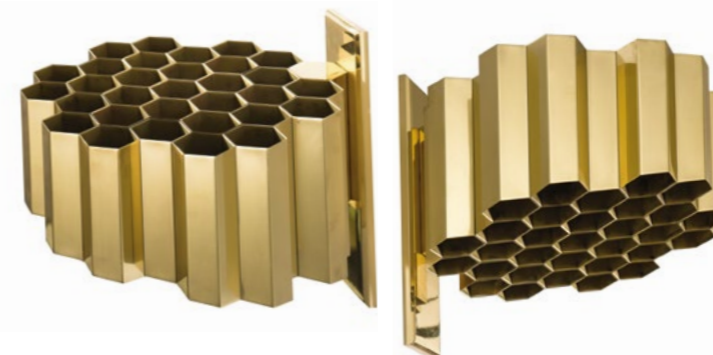

(Polished Brass) TOP/BOTTOM  
Length (L) \ 270 mm

## HONEYCOMB LAMP

Composed of 32 hexagonal tubes brazed by hand, this iconic lamp was designed in 1953 for the high entrance hall of the Declercq's house built by André Jacquain and Jules Wabbes.

To ensure it could be seen from both below and above, Jules Wabbes designed a lamp made of soldered hexagonal tube sections, so that the light source (bulb) is filtered from both sides by the metallic structure.

The Honeycomb Wall Lamp, a classic and an exclusivity of GENERAL DECORATION, is available in Nickel-plated Brass and Polished Brass.

1953

## TECHNICAL SPECS

NAME Honeycomb Wall Lamp  
ORIGINAL DESIGN 1953  
MATERIAL Brass

DIMENSIONS  
(L) 270 × (D) 254 × (H) 250 [mm]  
(L) 10.65 × (D) 10.00 × (H) 9.85 ["]  
WEIGHT 4.5 kg / 9.92 lbs

FINISHES / PRODUCT REF.  
Polished Brass | HWL-PB  
Nickel-plated Brass | HWL-NPB

PRODUCTION / EDITION On Demand

LIFESTYLE SEE P. 16-19

**GENERAL DECORATION**  
**BY JULES WABBES**

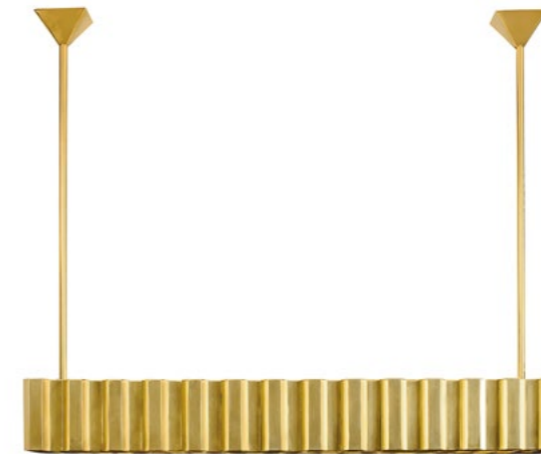
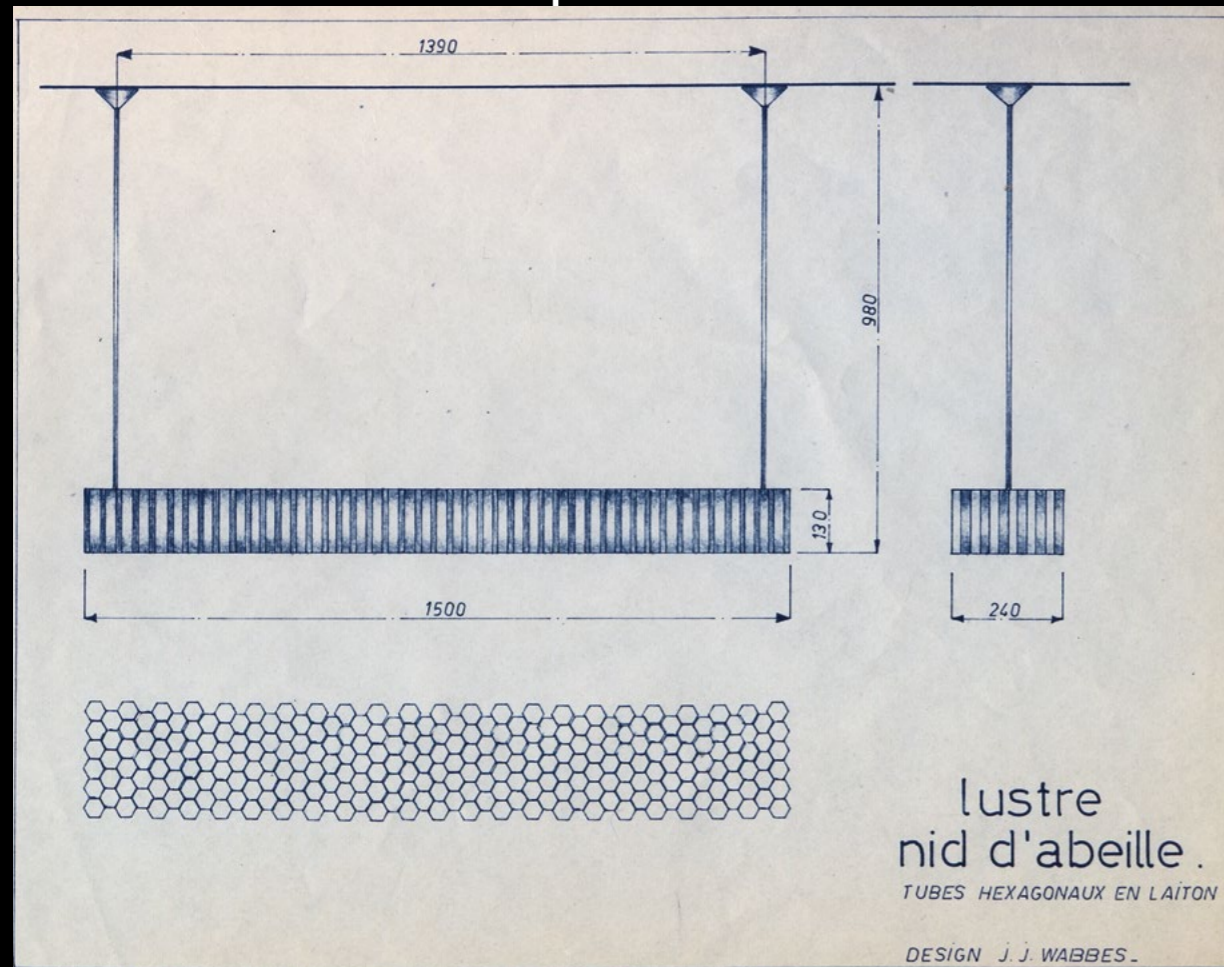

(Polished Brass)	FRONT
Length (L)	→ 900 mm 1500 mm
Height (H)	I 130 mm



(Polished Brass)	LEFT
Width (W)	↗ 240 mm

**HONEYCOMB CEILING LAMP**

Composed of hexagonal tubes welded together, the Honeycomb Ceiling Lamp is hung by two rods from the ceiling. Its structure is identical to Jules Wabbes' wall lamps, designed in 1953.

The first copy of this ceiling light was probably created in 1968 for the private office of Louis De Poortere fitted out by Wabbes in Kortrijk, Belgium. The model was later sold to corporate executive offices.

The golden light scattered by the honeycomb is particularly warm and celestial. A model of this kind was exhibited at the Wabbes retrospective in 2012 at the Palace of Fine Arts (Bozar) in Brussels.

**1968**

TECHNICAL SPECS

NAME	Honeycomb Ceiling Lamp
ORIGINAL DESIGN	1968
MATERIAL	Brass

DIMENSIONS	
(L) 900 × (W) 240 × (H) 130 [mm]	
(L) 35.43 × (W) 9.45 × (H) 5.10 ["]	
(L) 1500 × (W) 240 × (H) 130 [mm]	
(L) 59.00 × (W) 9.45 × (H) 5.10 ["]	

WEIGHT	11.7 kg / 24.25 lbs 17.0 kg / 37.48 lbs
--------	--

FINISHES / PRODUCT REF.	Polished Brass   HCL
-------------------------	----------------------

PRODUCTION / EDITION	On Demand
----------------------	-----------

LIFESTYLE SEE P. 20-23

**GENERAL DECORATION  
BY JULES WABBES**



HONEYCOMB CEILING LAMP

Assembling honeycomb tubes in the matrix

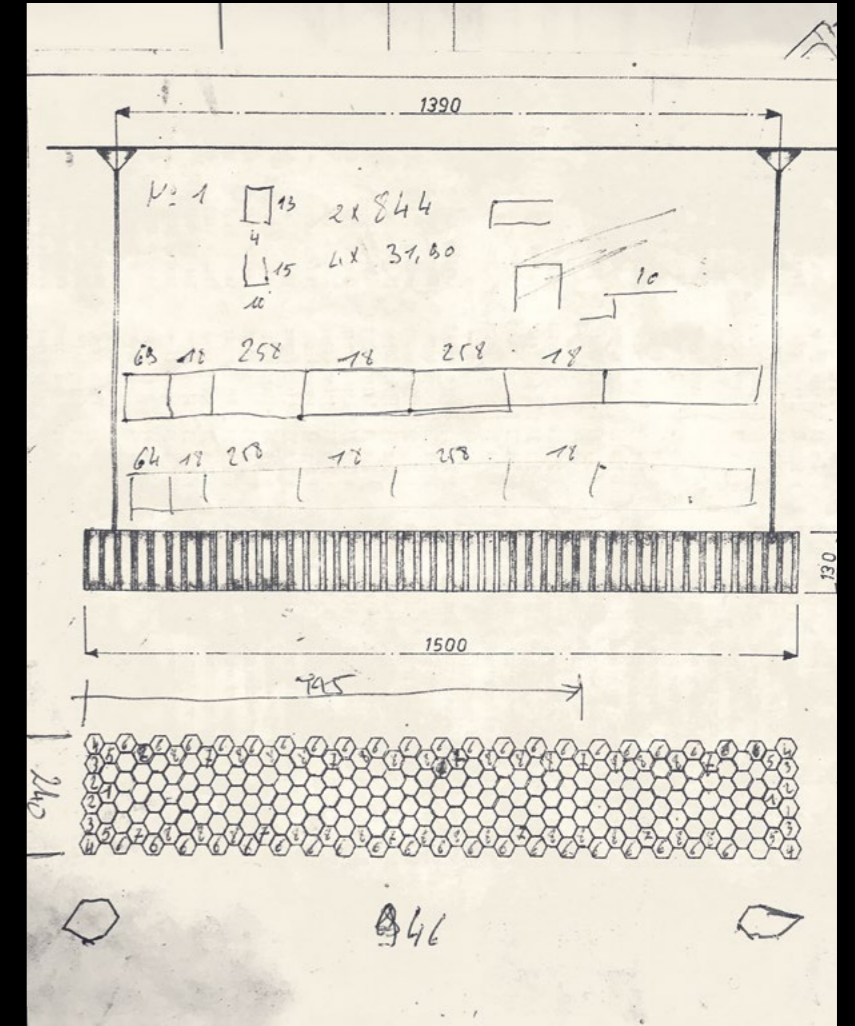

## LUSTRE HEXAGONAL

(grand modèle)

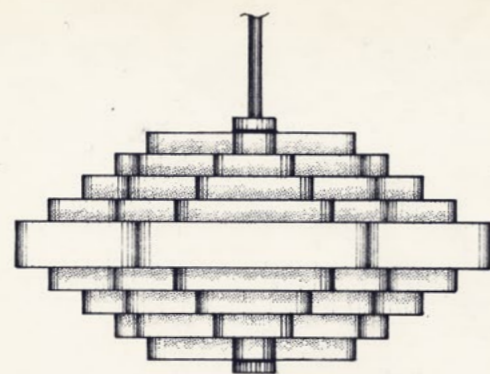

25

56

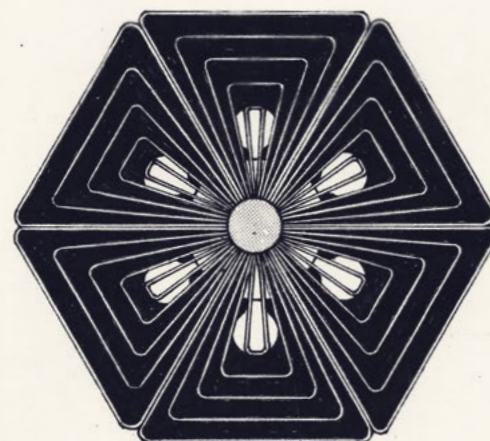

50

DECORS : INOX POLI . LAITON POLI SATINÉ

## GENERAL DECORATION

RUE DE MIDDELBOURG 48. 1170 BRUXELLES TEL : 73.61.40

LIMITED EDITION

## OSAKA CEILING LAMP



(Brushed Brass)

FRONT

Length (L)	595 mm
Height (H)	280 mm



(Brushed Brass)

TOP

Width (W)	525 mm
-----------	--------

## OSAKA CEILING LAMP

The Osaka Ceiling Lamp was created for the World Expo in Japan in 1970, with the theme: Progress and Harmony for Humanity. It was the first time the exhibition was held in Japan. The great architect Kenzo Tange was the artistic director. Jules Wabbes designed for the Belgian pavilion, whose architect was his former partner André Jacquain, this magnificent golden hexagonal chandelier. The Osaka chandelier represents the culmination of lighting previously designed by the Belgian designer using folded metal strips.

Here, the assembly work is very intricate. All the pieces revolve around the central axis. The reflections projected on the ceiling create a magical atmosphere. The chandelier floods the room with golden rays. A jewel of craftsmanship for the ceiling.

1970

## TECHNICAL SPECS

NAME	Osaka Ceiling Lamp
ORIGINAL DESIGN	1970
MATERIAL	Brass

## DIMENSIONS

(L) 595 × (W) 525 × (H) 280 [mm]
(L) 23.50 × (W) 20.65 × (H) 11.00 ["]
WEIGHT 24 kg / 52.91 lbs

FINISHES / PRODUCT REF.
Brushed Brass   OCL-BB
Nickel-plated Brass   OCL-NPB

PRODUCTION / EDITION	On Demand
----------------------	-----------

LIFESTYLE SEE P. 32-33

**GENERAL DECORATION**  
BY JULES WABBES

**LARGE ROUND BRASS PENDANT**

The round pendant lamp is composed of a series of brass circles. The source of light is protected and hidden by the metal circles. Hanging on a metal rod. Different heights and two sizes are available.

**1968**



(Brushed Brass) FRONT  
 Length (L) 440 mm  
 Height (H) 375 mm

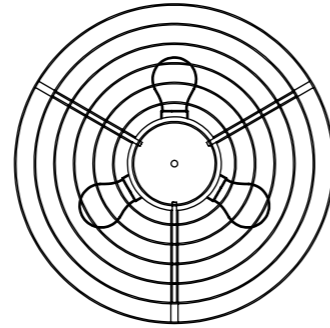

(Large Size) BOTTOM  
 Diameter (D) 440 mm

TECHNICAL SPECS

NAME Large Round Brass Pendant  
 ORIGINAL DESIGN 1968  
 MATERIAL Brass

DIMENSIONS (D) 440 × (H) 375 [mm]  
 (D) 17.30 × (H) 14.75 ["]  
 WEIGHT 12 kg / 26.46 lbs

FINISHES / PRODUCT REF.  
 Brushed Brass | LRP-BB  
 Nickel-plated Brass | LRP-NPB  
 Polished Brass | LRP-PB

PRODUCTION / EDITION On Demand

**GENERAL DECORATION  
 BY JULES WABBES**

LIFESTYLE SEE P. 34-37

**SMALL ROUND BRASS PENDANT**



(Nickel-plated Brass) FRONT  
 Length (L) 330 mm  
 Height (H) 254 mm

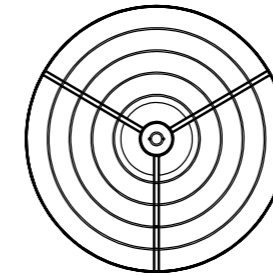

(Small Size) TOP  
 Diameter (D) 330 mm

TECHNICAL SPECS

NAME Small Round Brass Pendant  
 ORIGINAL DESIGN 1968  
 MATERIAL Brass

DIMENSIONS (D) 330 × (H) 254 [mm]  
 (D) 13.00 × (H) 10 ["]  
 WEIGHT 5.4 kg / 11.91 lbs

FINISHES / PRODUCT REF.  
 Brushed Brass | SRP-BB  
 Nickel-plated Brass | SRP-NPB  
 Polished Brass | SRP-PB

PRODUCTION / EDITION On Demand

**GENERAL DECORATION  
 BY JULES WABBES**

LIFESTYLE SEE P. 34-37

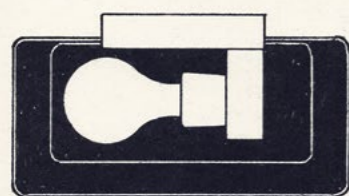
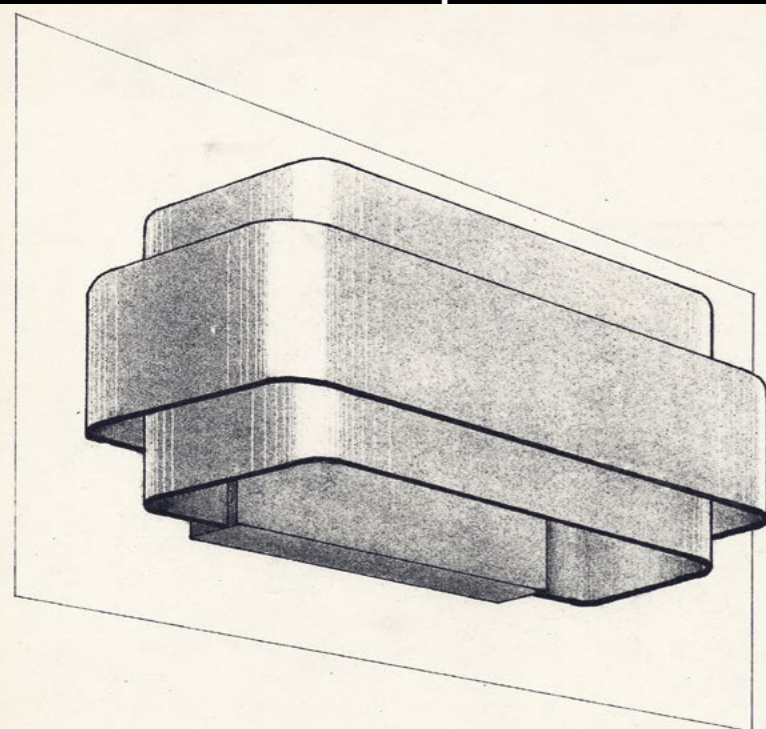

198

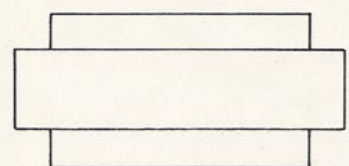

108

96

Tarif 1976  
 DECORS : LAITON : 4.400 F (hors TVA)  
 CHROME : 4.900 F (hors TVA)  
 NICKEL

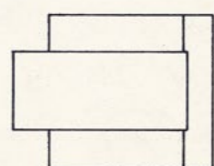

GENERAL DECORATION  
 Rue de Middelbourg 48  
 1170 Bruxelles

Tel : 673.61.40



(Nickel-plated Brass) FRONT  
 Length (L) 200 mm  
 Height (H) 106 mm



(Polished Brass) LEFT  
 Depth (D) 110 mm

MINI WALL LAMP

The Mini Wall Lamp is composed of three curved brass sheets, like the larger version of the wall lamp made of eleven parts and designed by Jules Wabbes in 1968.

Originally available in polished brass and nickel-plated brass, it is now also available in brushed brass.

This lamp was designed for General Decoration in 1969.

1969

TECHNICAL SPECS

NAME Mini Wall Lamp  
 ORIGINAL DESIGN 1968  
 MATERIAL Brass

DIMENSIONS  
 (L) 200 × (D) 110 × (H) 106 [mm]  
 (L) 7.87 × (D) 4.35 × (H) 4.20 ["]  
 WEIGHT 2.0 kg / 4.41 lbs

FINISHES / PRODUCT REF.  
 Polished Brass | MWL-PB  
 Nickel-plated Brass | MWL-NPB  
 Brushed Brass | MWL-BB

PRODUCTION / EDITION On Demand

LIFESTYLE SEE P. 24-27

GENERAL DECORATION  
 BY JULES WABBES

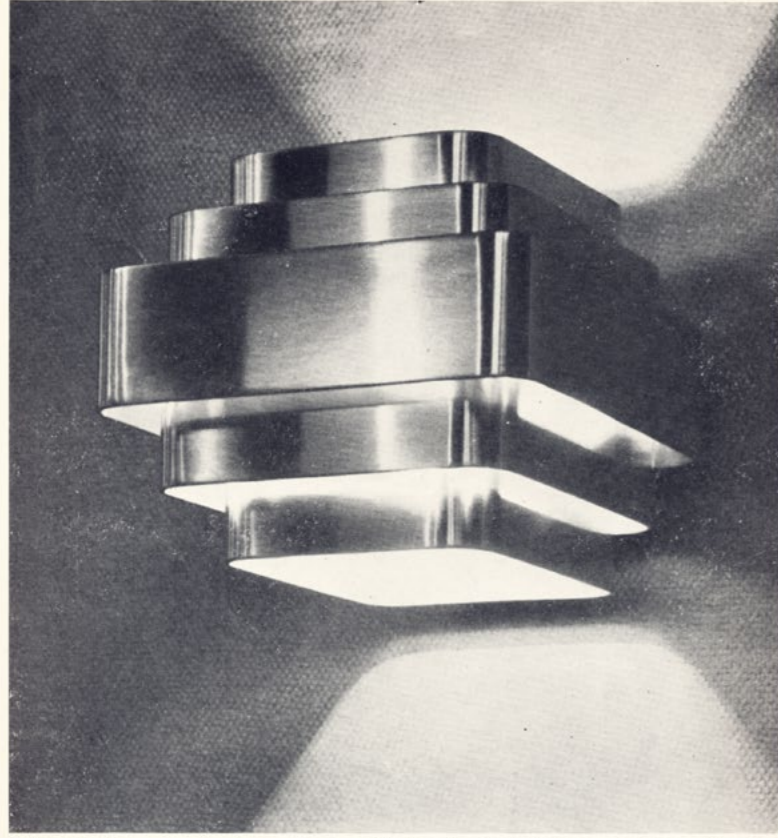

APPLIQUE PETIT MODELE

DECORS	ALUMINIUM	LAITON	CHROME
--------	-----------	--------	--------

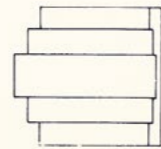
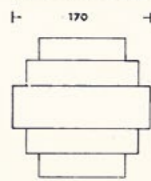

LIMITED EDITION



(Nickel-plated Brass) FRONT  
 Length (L) 173 mm  
 Height (H) 150 mm



(Polished Brass) FRONT  
 Depth (D) 189 mm

LIFESTYLE SEE P. 28-29

5-BAND WALL LAMP

This small Wall Lamp made of five curved brass bands looks more like a square in comparison with the Mini Wall Lamp and the 11-Band Wall Lamp. It belongs to the same family. Designed around 1968, the light is softly diffused through the shiny metal bands and forms beautiful shades. This lamp is like a ring for a wall.

1968

TECHNICAL SPECS

NAME 5-Band Wall Lamp  
 ORIGINAL DESIGN 1968  
 MATERIAL Brass

DIMENSIONS  
 (L) 173 × (D) 189 × (H) 150 [mm]  
 (L) 6.80 × (D) 7.50 × (H) 5.90 ["]  
 WEIGHT 2.3 kg / 5.07 lbs

FINISHES / PRODUCT REF.  
 Polished Brass | 5BWL-PB  
 Nickel-plated Brass | 5BWL-NPB  
 Brushed Brass | 5BWL-BB

PRODUCTION / EDITION On Demand

GENERAL DECORATION  
 BY JULES WABBES

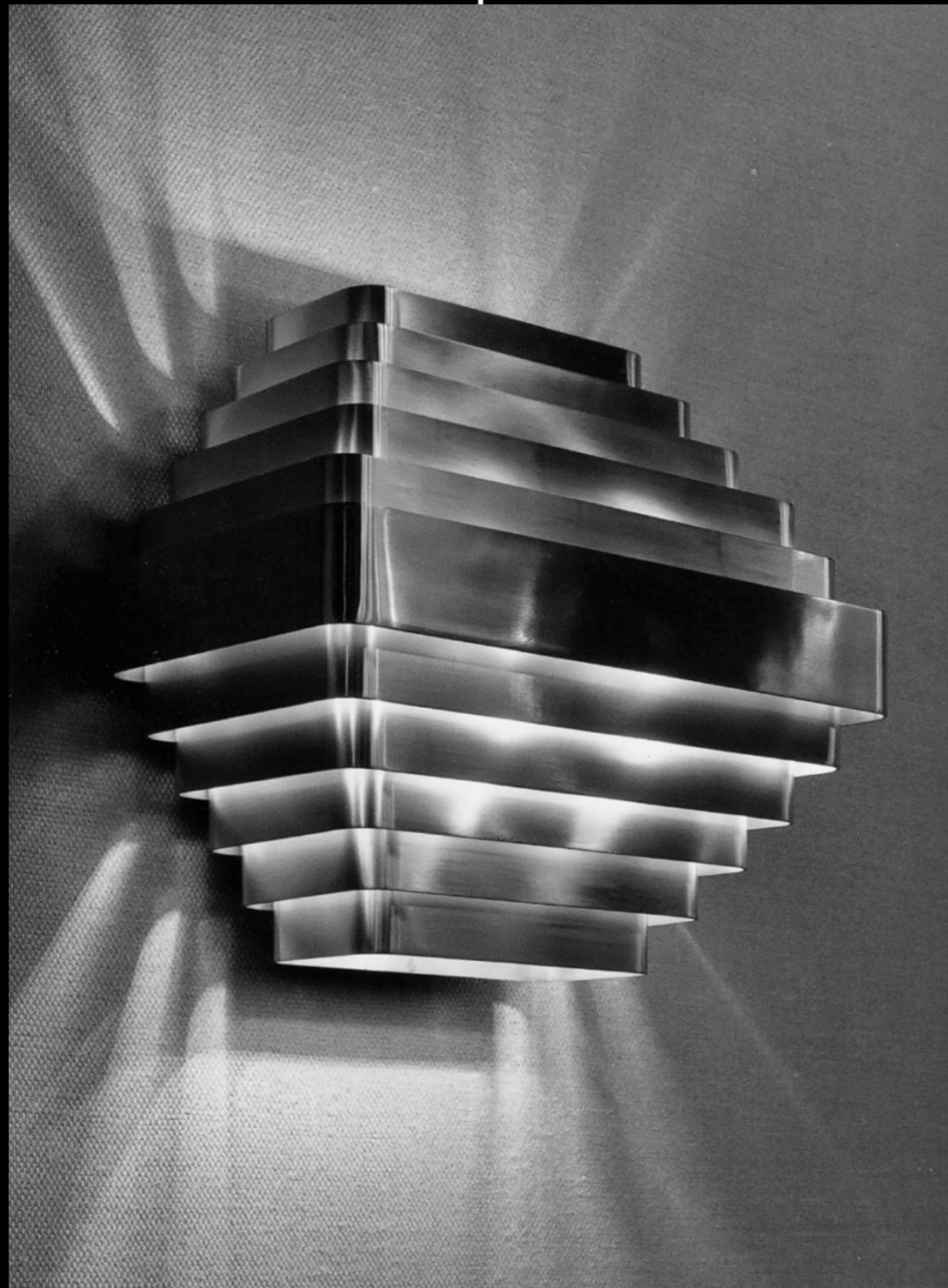

(Nickel-plated Brass) LEFT  
 Length (L) — 350 mm  
 Height (H) I 300 mm



(Polished Brass) FRONT  
 Depth (D) \ 181 mm

## 11-BAND WALL LAMP

The large Wall Lamp is composed of eleven curved brass bands. It was designed in 1968 for the Mobilier Universel and became part of General Decoration's catalogue. The lamp's design follows a common principle to the Honeycomb Wall Lamp that is how shades are projected on the wall in a sculptural manner.

1968

### TECHNICAL SPECS

NAME 11-Band Wall Lamp  
 ORIGINAL DESIGN 1968  
 MATERIAL Brass

DIMENSIONS  
 (L) 350 × (D) 181 × (H) 300 [mm]  
 (L) 13.80 × (D) 7.20 × (H) 11.80 ["]  
 WEIGHT 6.5 kg / 14.33 lbs

FINISHES / PRODUCT REF.  
 Nickel-plated Brass | 11BWL-NPB  
 Polished Brass | 11BWL-PB

PRODUCTION / EDITION On Demand

LIFESTYLE SEE P. 30-31

**GENERAL DECORATION  
 BY JULES WABBES**



DESIGNED, MANUFACTURED AND ASSEMBLED IN BELGIUM



## **GENERAL DECORATION**

### **HEAD OFFICE**

Route de Beaumont, 20  
1380 Lasne – Belgium  
+32 2 633 11 73  
info@juleswabbes.com

### **SHOWROOM**

Place Brugmann, 5  
1050 Brussels – Belgium

### **PHOTOGRAPHY**

Serge Anton  
Tine Claerhout  
Philippe D - Photography  
Bernard De keyser  
Michel Figuet  
Nicolas Schimp  
Andy Simon  
Brice Vandemeeren  
Frederik Vercruysse

### **TECHNICAL DRAWINGS**

Quentin De Moyer

### **TEXT**

© Marie Ferran-Wabbes

### **GRAPHIC DESIGN**

Neutre.be

# **GENERAL DECORATION**