

## SERIES 800 LUXURY SOFAS





This series, which can be ordered according to space and needs, with or without armrests, as a corner sofa, in one, two or three seats, is made of first-class latex foam with feather cushions for back support. Luxury comes from their depth and the refinement of the details (type of fabric or leather), smooth lacquered wood, brass clogs, solid but discreet stitching.

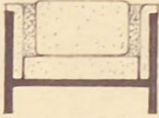
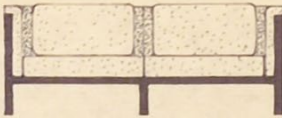

# Jules Wabbes

GENERALDECORATION

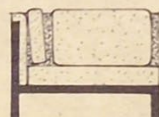

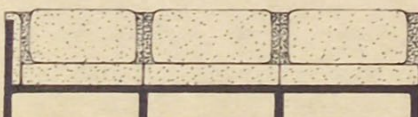
CANAPÉS J. J. WABBES. SERIE . 800 . LUXE		GARNISSAGES	
TYPES		CUIR	TISSU
			88.L
88 x 88 cm.			
	882.L		
165 x 88 cm.			
	883.L		
195 x 88 cm.			
	88.L.G. 1. accouoir.		
88 x 88 cm.			
	882.L.G. accouoir a gauche		
165 x 88 cm.	882.L.D. accouoir a droite		
	883.L.G. accouoir a gauche.		
245 x 88 cm.	883.L.D. accouoir a droite.		
DESIGN J. J. WABBES.		S. A. MOBILIER UNIVERSEL. 6, Boulevard du Régent. 1.000. Bruxelles. Tel : 12.72.60. 12.44.45.	



Left page:  
Original drawing,  
by Jules Wabbes, 1965

Above: Footstool,  
European oak



**FOOTSTOOL**

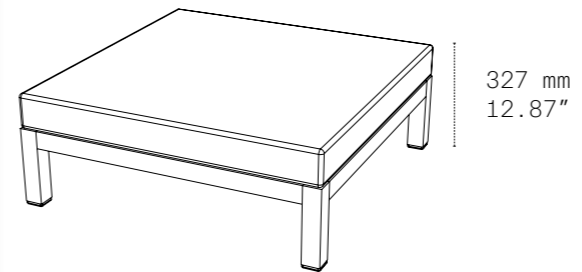

**ARMCHAIR**

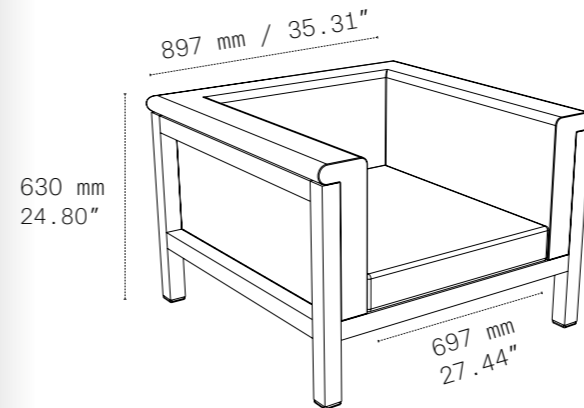

Left page: Armchair,  
European oak



The fabric is woven in Belgium.  
Made from 91% linen and 9% polyamide

Above: Armchair +  
Footstool, European oak



Above: 3-Seater Sofa  
+ Armchair, Ebonized oak





**3-SEATER SOFA**

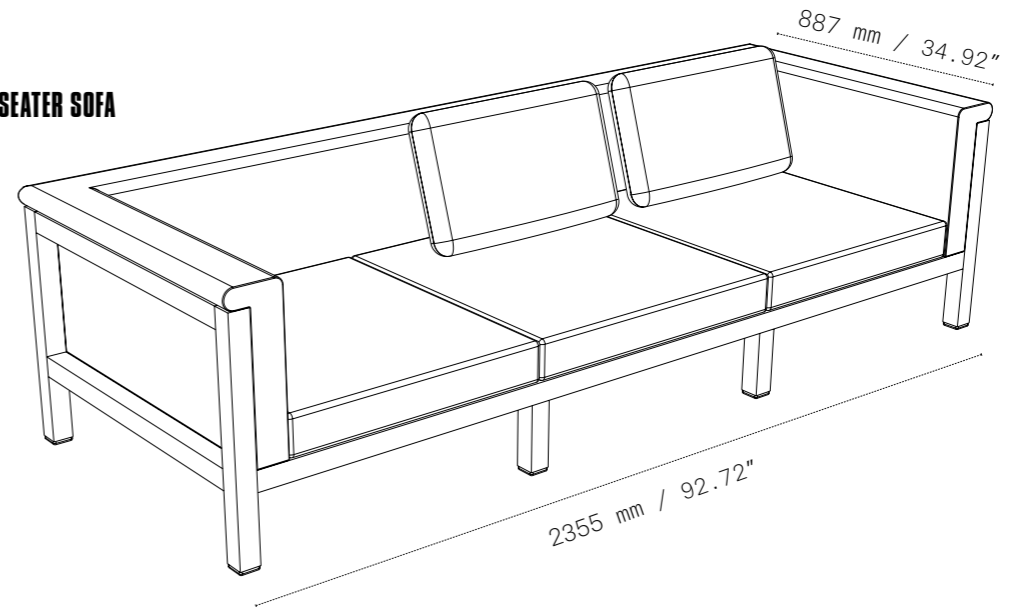

**3-SEATER MERIDIAN**

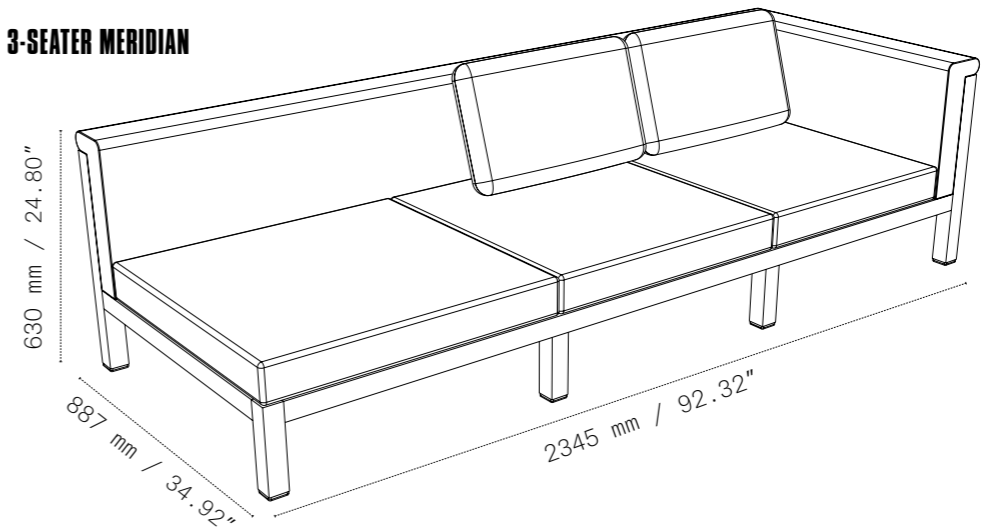

Left page: 3-Seater Sofa,  
Ebonized oak



Corner + two  
2-Seater Meridians,  
Ebonized oak



**2-SEATER SOFA**

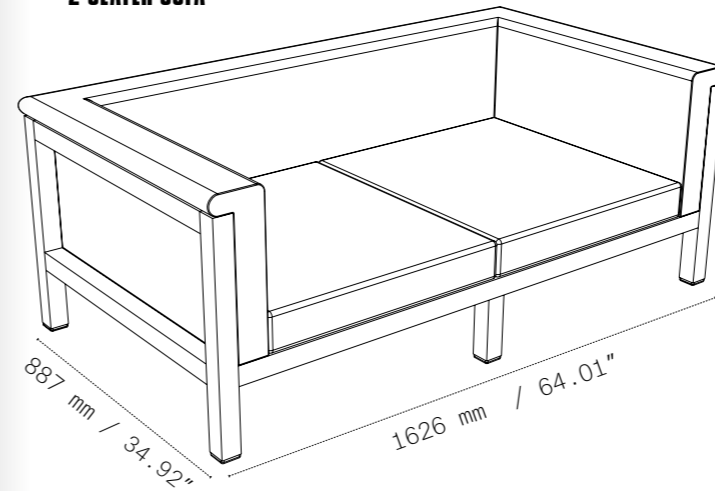

Left:  
2-seater sofa,  
Ebonized oak

Above:  
Vintage photography,  
CBR Building, Brussels



## SERIES 800 LUXURY SOFAS

Jules Wabbes used to utilise the models of other designers who had proven themselves in these layouts. He first used Finnish sofas and then quite quickly, in 1959, armchairs designed by the American Edward J. Wormley for Dunbar. Dunbar armchairs and sofas are so well integrated into his interiors that they are still mistaken for Wabbes models today.

Sofas are essential in an interior, because they are meant to accommodate the body, the bodies. They should be comfortable, but not too soft either. The client had to be able to sit on it as well as lie down. The designer had to find the right balance.



## GENERAL DECORATION

### HEAD OFFICE

Route de Beaumont, 20  
1380 Lasne – Belgium  
+32 2 633 11 73  
info@juleswabbes.com

### SHOWROOM

Place Brugmann, 5  
1050 Brussels – Belgium



Made from 91% linen  
and 9% polyamide

## CREDITS

Photos by Nicolas Schimp

Texts: Marie Ferran-Wabbes

Graphic design: Neutre.be

Technical drawings: Quentin De Moyer

### 100% MADE IN BELGIUM



European oak



Ebonized oak